

This publication contains the installation, operation and maintenance instructions for standard units of the *FCED*, *FCEB*, *FCRUD* and *FCRUB* Fiberglass Roof Exhausters.



**Carefully read this publication and any supplemental documents prior to any installation or maintenance procedure.**

Loren Cook catalog, *Fiberglass*, provides additional information describing the equipment, fan performance, available accessories and specification data.

For additional safety information, refer to AMCA Publication 410-96, *Safety Practices for Users and Installers of Industrial and Commercial Fans*.

All of the publications listed above can be obtained from:

- [lorencook.com](http://lorencook.com)
- [info@lorencook.com](mailto:info@lorencook.com)
- 417-869-6474 ext. 166

For information and instructions on special equipment, contact Loren Cook Company at 417-869-6474.

### Receiving and Inspection

Carefully inspect the fan and accessories for any damage and shortage immediately upon receipt of the fan.

- Turn the wheel by hand to ensure it turns freely and does not bind.
- Check dampers (if supplied) for free operation of all moving parts.
- Record on the *Delivery Receipt* any visible sign of damage.

### Handling

Lift the fan by the base.

**NOTICE! Never lift by the shaft, motor or housing.**

### Storage

If the fan is stored for any length of time prior to installation, completely fill the bearings with grease or moisture-inhibiting oil (refer to *Lubricants*, page 6). Rotate the wheel several revolutions every three to five days to keep a coating of grease on all internal bearing parts.

Store the fan in its original crate and protect it from dust, debris and weather.



**FCE**



**FCRU**

## **!WARNING**

### Rotating Parts & Electrical Shock Hazard:

Fans should be installed and serviced by qualified personnel only.

Disconnect electric power before working on unit (prior to removal of guards or entry into access doors).

Follow proper lockout/tagout procedures to ensure the unit cannot be energized while being installed or serviced.

A disconnect switch should be placed near the fan in order that the power can be swiftly cut off, in case of an emergency and in order that maintenance personnel are provided complete control of the power source.

Grounding is required. All field-installed wiring must be completed by qualified personnel. All field installed wiring must comply with National Electric Code (NFPA 70) and all applicable local codes.

Fans and blowers create pressure at the discharge and vacuum at the inlet. This may cause objects to get pulled into the unit and objects to be propelled rapidly from the discharge. The discharge should always be directed in a safe direction and inlets should not be left unguarded. Any object pulled into the inlet will become a projectile capable of causing serious injury or death.

When air is allowed to move through a non-powered fan, the impeller can rotate, which is referred to as windmilling. Windmilling will cause hazardous conditions due to unexpected rotation of components. Impellers should be blocked in position or air passages blocked to prevent draft when working on fans.

Friction and power loss inside rotating components will cause them to be a potential burn hazard. All components should be approached with caution and/or allowed to cool before contacting them for maintenance.

Under certain lighting conditions, rotating components may appear stationary. Components should be verified to be stationary in a safe manner, before they come into contact with personnel, tools or clothing.

Failure to follow these instructions could result in death or serious injury.

The attachment of roof mounted fans to the roof curb as well as the attachment of roof curbs to the building structure must exceed the structural requirements based on the environmental loading derived from the applicable building code for the site. The local code official may require variations from the recognized code based on local data. The licensed engineer of record will be responsible for prescribing the correct attachment based on construction materials, code requirements and environmental effects specific to the installation.

To maintain good working condition of the fan when it is stored outdoors, follow the additional instructions below.

- Coat the shaft with grease or a rust preventative compound.
- Wrap bearings for weather protection. Cover the inlet and outlet to prevent the accumulation of dirt and moisture in the housing.
- Periodically rotate the wheel and operate dampers (if supplied). Periodically inspect the unit to prevent damaging conditions.

## Installation

If the fan was delivered with the motor unmounted, see the maintenance section for belt and pulley installation.

### Damper Installation

If your fan is supplied with dampers, follow the directions below. If your fan does not include dampers, proceed to *Belt and Pulley Installation*.

1. Place the damper inside the curb or inside the duct work. Ensure the damper will open freely for the correct direction of the airflow.
2. Secure to curb at the damper shelf.
3. Drill hole in the curb shelf for conduit needed for motor wiring.
4. Operate the dampers manually to ensure the blades move freely.
5. Install fan over curb while aligning the conduit location with the conduit hole in the curb.

### Wiring Installation



**NOTICE!** All wiring should be in accordance with local ordinances and the National Electrical Code, NFPA 70. Ensure the power supply (voltage, frequency, and current carrying capacity of wires) is in accordance with the motor nameplate (see page 3 for diagram). Fan must be grounded to prevent electrical discharge.

#### For Units Without A Junction Box:

An approved metal field wiring compartment must be secured to the unit with two screws in order that the box does not rotate. All wires must be protected from abrasion where they enter and exit the wiring compartment.

The green ground wire from the motor must be secured under the green ground screws inside the field wiring compartment using a closed loop connector. Complete connections in accordance with the wiring diagram on the motor.

#### For Units With A Junction Box:

Pull wires through the appropriate conduit. Protect wires from abrasion where they enter the field wiring compartment and complete connections in accordance with the diagram on the motor.

Leave enough slack in the wiring to allow for motor movement when adjusting belt tension. Some fractional motors have to be removed in order to make the connection with the terminal box at the end of the motor.



**NOTICE!** Follow the wiring diagram in the disconnect switch and the wiring diagram provided with the motor. Correctly label the circuit on the main power box and always identify a closed switch to promote safety (i.e., red tape over a closed switch).

1. Remove the top cap which covers the motor assembly by unbolting the lid.
2. For internal wiring, run the electrical wire and conduit through the opening drilled in the damper shelf (refer to Damper Installation), then through the wiring conduit in the ventilator base to the motor compartment. For external wiring, run the wires through the horizontal conduit on upblast units, or under top cap in downblast units.
3. Pull the wires through and complete the wiring. For further information. Refer to *Wiring Diagrams* on page 3.

### Final Installation Steps

1. Ensure fasteners and set screws, particularly fan mounting and bearing fasteners are tightened according to the recommended torque shown on the table below.
2. Inspect for correct amperage with an ammeter and correct voltage with a voltmeter.
3. Ensure that all accessories are installed.
4. Test the fan to be sure the rotation is the same as indicated by the arrow marked "Rotation."



**NOTICE!** Do not allow the fan to run in the wrong direction. This will overheat the motor and cause serious damage. For 3-phase motors, if the fan is running in the wrong direction, check the control switch. It is possible to interchange two leads at this location so that the fan is operating in the correct direction.

5. Inspect wheel-to-inlet clearance. Wheels may shift in shipment. To realign wheel-to-inlet, shift upper bearing so there is an equal radial clearance between the wheel and inlet. Refer to *Wheel to Inlet Clearance*, page 6.

#### Recommended Torque for Setscrews/Bolts on Metal (IN-LB)

Size	Key Hex Across Flats	Setscrews		Hold Down Bolts	
		Recommended Torque		Size	Recommended Torque
		Min.	Max.		
#8	5/64"	15	21	3/8"-16	324
#10	3/32"	27	33	1/2"-13	780
1/4	1/8"	70	80	5/8"-11	1440
5/16	5/32"	140	160	3/4"-10	2400
3/8	3/16"	250	290	7/8"-9	1920
7/16	7/32"	355	405	1"-8	2700
1/2	1/4"	560	640	1-1/8"-7	4200
5/8	5/16"	1120	1280	1-1/4"-7	6000
3/4	3/8"	1680	1920	-	-
7/8	1/2"	4200	4800	-	-
1	9/16"	5600	6400	-	-

#### Recommended Torque for Setscrews/Bolts on FRP (FT-LB)

Size (inches)	18-8 SST Hardware Torque
No. 10	7
1/4"	12
5/16"	20
3/8"	30
7/16"	41
1/2"	54
5/8"	86
3/4"	128

# Wiring Diagrams

## Single Speed, Single Phase Motor

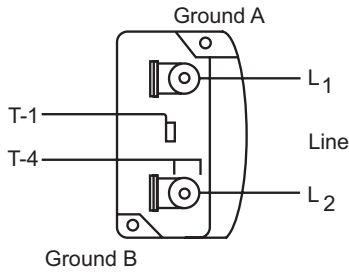

When ground is required, attach to ground A or B with No. 6 thread forming screw. To reverse, interchange T-1 and T-4.

## 2 Speed, 2 Winding, Single Phase Motor

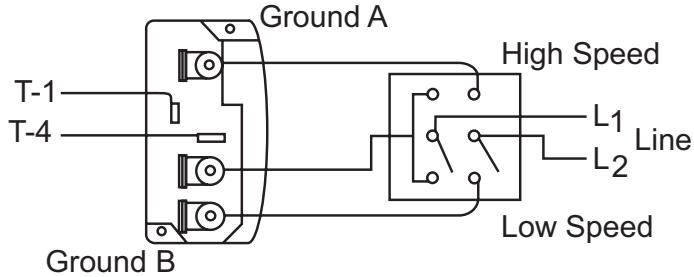

When ground is required, attach to ground A or B with No. 6 thread forming screw. To reverse, interchange T-1 and T-4 leads.

## Single Speed, Single Phase, Dual Voltage

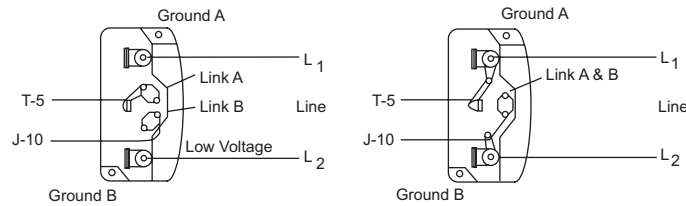

When ground is required, attach to ground A or B with No. 6 thread forming screw. To reverse, interchange T-5 and J-10 leads.

## Typical Damper Motor Schematic

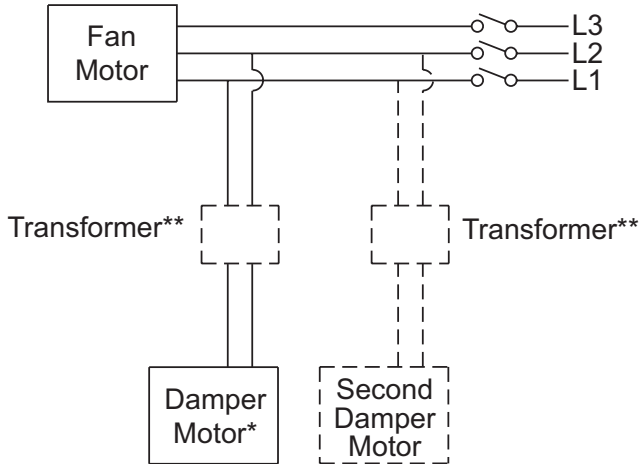

For 3 Phase, damper motor voltage should be the same between L<sub>1</sub> and L<sub>2</sub>. For single phase application, disregard L<sub>3</sub>.

\*Damper motors may be available in 115, 230 and 460 volt models. The damper motor nameplate voltage should be verified prior to connection.

\*\*A transformer may be provided in some installations to correct the damper motor voltage to the specified voltage.

## 3 Phase, 9 Lead Motor

### 3 Phase, 9 Lead Motor Y-Connection

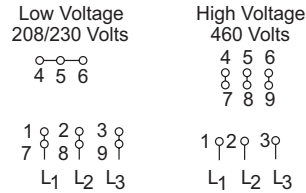

### 3 Phase, 9 Lead Motor Delta-Connection

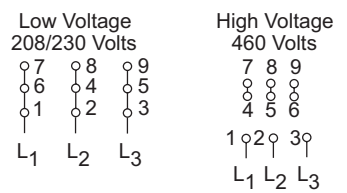

To reverse, interchange any 2 line leads.

## 2 Speed, 1 Winding, 3 Phase Motor

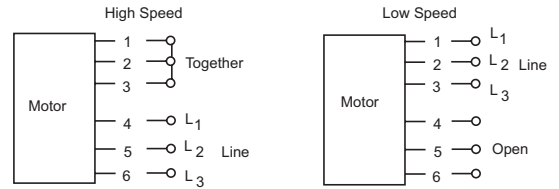

To reverse, interchange any 2 line leads. Motors require magnetic control.

## 2 Speed, 2 Winding, 3 Phase

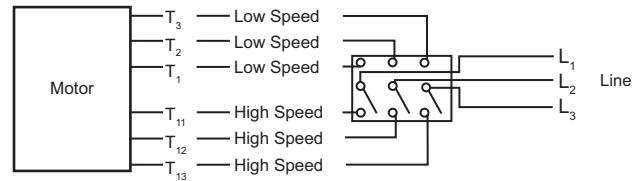

To reverse: High Speed-interchange leads T<sub>11</sub> and T<sub>12</sub>. Low Speed-interchange leads T<sub>1</sub> and T<sub>2</sub>. Both Speeds-interchange any 2 line leads.

## Operation

### Pre-Start Checks

1. Lock out all the primary and secondary power sources.
2. Inspect and tighten fasteners and setscrews, particularly fan mounting and bearing fasteners. Refer to *Torque Chart*.
3. Inspect belt tension and pulley alignment. Refer to *Belt and Pulley Installation*, page 5.
4. Inspect motor wiring. Refer to *Wiring Installation*.
5. Ensure belt touches only the pulleys.
6. Rotate the wheel to ensure it rotates freely.
7. Ensure fan and ductwork are clean and free of debris.
8. Close and secure all access doors.
9. Restore power to fan.

### Start-Up

Turn on the fan. In variable speed units, set the fan to its lowest speed. Inspect for the following:

- Direction of rotation
- Excessive vibration
- Unusual noise
- Bearing noise
- Improper belt alignment or tension (listen for squealing)
- Improper motor amperage or voltage

**If a problem is discovered, immediately shut the fan off. Lock out all electrical power and check for the cause of the trouble. Refer to *Troubleshooting* on page 7.**

## Inspection

Inspection of the fan should be conducted at the first **30 minute, 8 hour and 24 hour** intervals of satisfactory operation. During the inspections, stop the fan and inspect as per the chart below.

### 30 Minute Interval

Inspect bolts, setscrews, and motor mounting bolts. Adjust and tighten as necessary.

### 8 Hour Interval

Inspect belt alignment and tension. Adjust and tighten as necessary.

### 24 Hour Interval

Inspect belt tension. Adjust and tighten as necessary.

## Maintenance

Establish a schedule for inspecting all parts of the fan. The frequency of inspection depends on the operating conditions and location of the fan.

Inspect fans exhausting corrosive or contaminated air within the first month of operation. Fans exhausting contaminated air (airborne abrasives) should be inspected every three months.

**It is recommended the following inspections be conducted twice per year:**

- Inspect bolts and setscrews for tightness. Tighten as necessary. Refer to *Torque chart*.
- Inspect belt wear and alignment. Replace worn belts with new belts and adjust alignment as needed. Refer to *Belt and Pulley Installation*, page 5.
- Bearings should be inspected as recommended in the *Conditions Chart*.
- Inspect for cleanliness. Clean exterior surfaces only. Removing dust and grease on motor housing assures proper motor cooling.

## Fan Bearings

**NOTICE!** *The fan bearings are provided prelubricated. Any specialized lubrication instructions on fan labels supersedes information provided herein. Bearing grease is a petroleum lubricant in a lithium base conforming to a NLGI #2 consistency. If user desires to utilize another type of lubricant, they take responsibility for flushing bearings and lines, and maintaining a lubricant that is compatible with the installation.*

A NLGI #2 grease is a light viscosity, low-torque, rust-inhibiting lubricant that is water resistant. Its temperature range is from -30°F to 200°F and capable of intermittent highs of 250°F.



Bearings should be relubricated in accordance with the condition chart below.

### Conditions Chart

RPM	Temp. °F	Greasing Interval
Up to 1000	-30 to 120	6 months
	120 to 200	2 months
1000 to 3000	-30 to 120	3 months
	120 to 200	1 month
Over 3000	-30 to 120	1 month
	120-200	2 weeks
Any Speed	< -30	Consult Factory
Any Speed	> 200	1 week

For moist or otherwise contaminated installations, divide the interval by a factor of 3. For vertical shaft installation, divide the interval by a factor of 2.

For best results, lubricate the bearing while the fan is in operation. Pump grease in slowly until a slight bead forms around the bearing seals. Excessive grease can damage seal and reduce life through excess contamination and/or loss of lubricant.

In the event that the bearing cannot be seen, use no more than three injections with a hand operated grease gun.

## Motor Bearings

Motor bearings without provisions for relubrication will operate up to 10 years under normal conditions with no maintenance. In severe applications, high temperatures or excessive contaminants, it is advisable to have the maintenance department disassemble and lubricate the bearings after 3 years of operation to prevent interruption of service.

For motors with provisions for relubrication, follow intervals of the following table.

### Relubrication Intervals

Service Conditions	Nema Frame Size					
	Up to and Including 184T		213T-365T		404T and Larger	
	1800 RPM and Less	Over 1800 RPM	1800 RPM and Less	Over 1800 RPM	1800 RPM and Less	Over 1800 RPM
Standard	3 yrs.	6 months	2 yrs.	6 months	1 yr.	3 months
Severe	1 yr.	3 months	1 yr.	3 months	6 months	1 month

**NOTICE!** *Motors are provided with a polyurea mineral oil NLGI #2 grease. All additions to the motor bearings are to be with a compatible grease such as Exxon Mobil Polyrex EM and Chevron SRI.*



The above intervals should be reduced to half for vertical shaft installations.

## Motor Services

Should the motor prove defective within a one-year period, contact your local Loren Cook representative or your nearest authorized electric motor service representative.

## Changing Shaft Speed

All belt driven ventilators (5HP or less) are equipped with variable pitch pulleys. To change fan speed, perform the following:

1. Loosen setscrew on driver (motor) pulley and remove key, if equipped.
2. Turn the pulley rim to open or close the groove facing. If the pulley has multiple grooves, all must be adjusted to the same width.
3. After adjustment, inspect for proper belt tension.

Size	Maximum RPM	
	Standard	HP Only
120	4500	4500
150	3600	4300
180	2900	3600
245	2200	2700 </td
270	2000	2400
300	1800	2200
330	1650	2000
365	1500	1800
402	1350	1650

## Speed Reduction

Open the pulley in order that the belt rides deeper in the groove (smaller pitch diameter).

## Speed Increase

Close the pulley in order that the belt rides higher in the groove (larger pitch diameter). Ensure that the RPM limits of the fan and the horsepower limits of the motor are maintained.

## Replacing Pulleys and Belts

1. Clean the motor and fan shafts.
2. Loosen the motor plate mounting bolts to relieve the belt tension. Remove the belt.
3. Loosen the pulley setscrews and remove the pulleys from the shaft. If excessive force is required to remove the pulleys, a three-jaw puller can be used. This tool, however, can easily warp a pulley. If the puller is used, inspect the trueness of the pulley after it is removed from the shaft. The pulley will need replacement if it is more than 0.020 inch out of true.
4. Clean the bores of the pulleys and place a light coat of oil on the bores.
5. Remove grease, rust and burrs from the shaft.
6. Place fan pulley on the fan shaft and the motor pulley on the motor shaft. Damage to the pulleys can occur when excessive force is used in placing the pulleys on their respective shafts.
7. After the pulleys have been correctly placed back onto their shafts, tighten the pulley setscrews.
8. Install the belts on the pulleys. Align and adjust the belts to the proper tension as described in *Belt and Pulley Installation*.

## Belt and Pulley Installation

Belt tension is determined by the sound of the belts when the fan is first started. The belts will produce a loud squeal, which dissipates after the fan is operating at full capacity. If belt tension is too tight or too loose, lost efficiency and damage may occur.

Do not change the pulley pitch diameter to change tension. The change will result in a different fan speed.

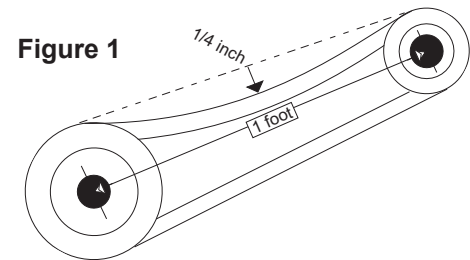
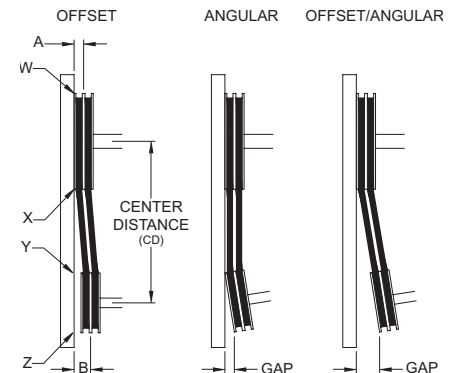

Figure 1

1. Loosen motor plate adjustment bolts and slide motor plate so that belts easily slip into the grooves on the pulleys. Never pry, roll, or force the belts over the rim of the pulley.
2. Slide motor plate until proper tension is reached. For proper tension, a deflection of approximately 1/4" per foot of center distance should be obtained by firmly pressing the belt. Refer to *Figure 1*.
3. Lock the motor plate adjustment bolts in place.
4. Ensure pulleys are properly aligned. Refer to *Figure 2*.

Figure 2

Center Distance	Max. Gap
Up through 12"	1/16"
12" up through 48"	1/8"
Over 48"	1/4"



## Pulley Alignment

Pulley alignment is adjusted by loosening the motor pulley setscrew and by moving the motor pulley on the motor shaft.

*Figure 2* indicates where to measure the allowable gap for the drive alignment tolerance. All contact points (indicated by WXYZ) are to have a gap less than the tolerance shown in the table. When the pulleys are not the same width, the allowable gap must be adjusted by half of the difference in width. *Figure 3* illustrates using a carpenter's square to adjust the position of the motor pulley until the belt *Figure 3* is parallel to the longer leg of the square.

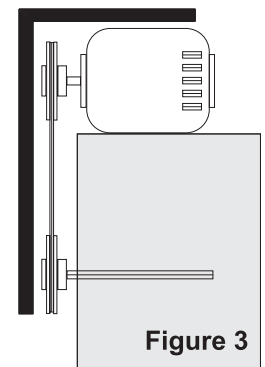

Figure 3

## Bearing Replacement

The fan bearings are pillow block ball bearings.

1. Follow all local lock-out/tag-out procedures, remove topcap from unit and unwire the units motor.
2. Loosen the bolts holding the motor and remove the belt. Inspect the belt for signs of wear and set aside.
3. While supporting the motor, either by the lifting eye or around the base on the motor, loosen and remove all the bolts holding the motor. Do not lift motor by its shaft. Caution: Motors with cast frames can be extremely heavy and should not be lifted without additional aid. Set motor aside.
4. Locate the 4 to 8 bolts on the flat surface of the interior of the housing. Begin to loosen these bolts and save the hardware. Note unit may shift during this process.
5. Using the lifting points on the power assembly carefully lift the assembly straight up until the wheel clears all parts of the unit. Set the wheel / shaft / power assembly down in a manner that does not damage the roof or any component.
6. Measure and record the distance of the wheel from the support plate.
7. Using a putty knife at the wheel hub, scrape the resin from the safety plate and retaining bolt.
8. Remove the retaining bolt and safety plate and set aside.
9. Using either a jewelry screw driver or small drill bit, remove the beeswax from the set screw openings and set screw heads.
10. Remove the wheel and remove the old bearings and shaft.
11. Install the new shaft to the wheel, safety plate, and retaining bolt. Tighten all per the torque values as stated on page 2.
12. Using a fiberglass resin repair kit, apply resin per the manufacture instruction over the safety plate, and retaining bolt. Recommend using a Grainger part number 3RAR9 or equal.
13. Reapply beeswax to protect the set screw heads.
14. Install the new shaft by sliding the bearings to the desired location using the measurement record earlier and loosely mounting the bearing support. Bearing bolts and bearing set screws should be loose enough to allow shaft position later.
15. Follow step 2 through 6 in reserve order to re-assemble unit. Please note the wheel to inlet clear matches as close as possible the diagram on page below
16. Tighten all hardware per the torque values as stated on page 2 and follow the *Operation Pre-Start Check* and *Start-Up* listed in this document.

## Wheel-to-Inlet Clearance

The correct wheel-to-inlet clearance is critical to proper fan performance. This clearance should be verified before initial start-up since rough handling during shipment could cause a shift in fan components. Refer to wheel/inlet drawing for correct overlap.

Adjust the overlap by loosening the wheel hub and moving the wheel along the shaft to obtain the correct value.

A uniform radial gap (space between the edge of the cone and the edge of the inlet) is obtained by loosening the bearing bolts and set screws which will allow for correct repositioning.

Size	Overlap
120-165	3/16"
180-245	1/4"
270-300	5/16"
330-365	3/8"
402	7/16"

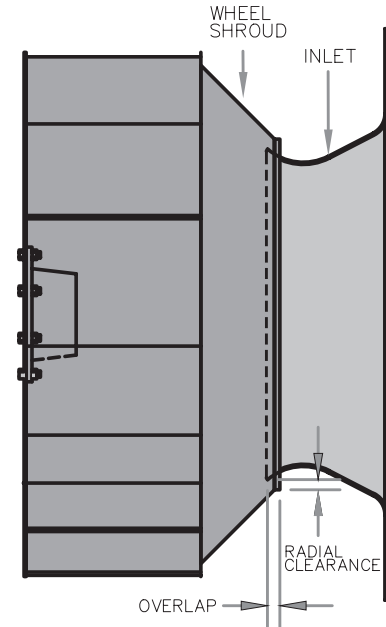

## Spare Parts

Spare parts are not needed for the first year of operation. If spare parts are desired, then it is suggested that a spare motor and impeller be ordered for direct drive fans. For belt drive fans, in addition to the motor and impeller, it is suggested that a spare set of bearings, shaft, sheaves and belts be ordered.

When ordering spare parts, specify the parts desired, the fan model number and the fan serial number. Contact your local sales representative for price and delivery.

# Troubleshooting

## Problem and Potential Cause

### **Low Capacity or Pressure:**

- Incorrect direction of rotation. Make sure the fan rotates in same direction as the arrows on the motor or belt drive assembly.
- Poor fan inlet conditions. There should be a straight clear duct at the inlet.
- Improper wheel alignment.

### **Excessive Vibration and Noise:**

- Damaged or unbalanced wheel.
- Belts too loose; worn or oily belts.
- Speed too high.
- Incorrect direction of rotation. Make sure the fan rotates in same direction as the arrows on the motor or belt drive assembly.
- Bearings need lubrication or replacement.
- Fan surge.

### **Overheated Motor:**

- Motor improperly wired.
- Incorrect direction of rotation. Make sure the fan rotates in same direction as the arrows on the motor or belt drive assembly.
- Cooling air diverted or blocked.
- Improper inlet clearance.
- Incorrect fan RPMs.
- Incorrect voltage.

### **Overheated Bearings:**

- Improper bearing lubrication
- Excessive belt tension.

## Limited Warranty

Loren Cook Company warrants that your Loren Cook fan was manufactured free of defects in materials and workmanship, to the extent stated herein. For a period of one (1) year after date of shipment, we will replace any parts found to be defective without charge, except for shipping costs which will be paid by you. This warranty is granted only to the original purchaser placing the fan in service. This warranty is void if the fan or any part thereof has been altered or modified from its original design or has been abused, misused, damaged or is in worn condition or if the fan has been used other than for the uses described in the company manual. This warranty does not cover defects resulting from normal wear and tear. To make a warranty claim, notify Loren Cook Company, General Offices, 2015 East Dale Street, Springfield, Missouri 65803-4637, explaining in writing, in detail, your complaint and referring to the specific model and serial numbers of your fan. Upon receipt by Loren Cook Company of your written complaint, you will be notified, within thirty (30) days of our receipt of your complaint, in writing, as to the manner in which your claim will be handled. If you are entitled to warranty relief, a warranty adjustment will be completed within sixty (60) business days of the receipt of your written complaint by Loren Cook Company. This warranty gives only the original purchaser placing the fan in service specifically the right. You may have other legal rights which vary from state to state. For fans provided with motors, the motor manufacturer warrants motors for a designated period stated in the manufacturer's warranty. Warranty periods vary from manufacturer to manufacturer. Should motors furnished by Loren Cook Company prove defective during the designated period, they should be returned to the nearest authorized motor service station. Loren Cook Company will not be responsible for any removal or installation costs.



# LOREN COOK COMPANY

Corporate Offices: 2015 E. Dale St. Springfield, MO 65803  
Phone 417-869-6474 | Fax 417-862-3820 | [lorencook.com](http://lorencook.com)