

COOK

Propeller Upblast

Upblast Propeller Roof Fans

INSTALLATION, OPERATION, AND MAINTENANCE MANUAL

This publication contains the installation, operation and maintenance procedures for standard units of the *Upblast - Upblast Propeller Roof Fans*.

- AUD
- EUB/AUB
- LXU/LEU
- SUB/SUBH
- TUD
- TUB

Carefully read this publication prior to any installation or maintenance procedure.

Loren Cook catalogs, *Propeller Upblast and Propeller Roof*, provide additional information describing the equipment, fan performance, available accessories and specification data.

For additional safety information, refer to AMCA publication 410-96, *Safety Practices for Users and Installers of Industrial and Commercial Fans*.

All of the publications listed above can be obtained from Loren Cook Company by phoning (417) 869-6474, extension 166; by FAX at (417) 832-9431; or by e-mail at info@lorencook.com.

For information and instructions on special equipment, contact Loren Cook Company at (417) 869-6474.

Receiving and Inspection

Carefully inspect the fan and accessories for any damage and shortage immediately upon receipt of the fan.

- Turn the propeller by hand to ensure it turns freely and does not bind.
- Check dampers (if included) for free operation of all moving parts.
- Record on the *Delivery Receipt* any visible sign of damage.

WARNING

This unit has rotating parts. Safety precautions should be exercised at all times during installation, operation, and maintenance. ALWAYS disconnect power prior to working on fan.

Handling

Lift propeller roof ventilators by the base or with slings placed around the fan housing. Never lift by the shaft, motor, propeller, or coupling.

If you use hooks in the lifting holes of the fan, be careful not to distort or bend the housing. Large units may have lifting lugs or holes that should be used instead of a sling.

If your fan has a special protective finish, **handle with extreme care**. Even a small chip will break the coating's continuity and destroy its ability to protect the metal.

Propellers are carefully balanced to give smooth, vibration-free operation. If the propeller is damaged during handling, it will require rebalancing.

Personal Safety

Disconnect switches are recommended. Place the disconnect switch near the fan in order that the power can be swiftly cut off in case of an emergency, and in order that maintenance personnel are provided complete control of the power source.

Storage

If the fan is stored for any length of time prior to installation, store it in its original shipping crate and protect it from dust, debris and the weather.

Outdoor Storage

To maintain good working condition of the fan when it is stored outdoors or at a construction site, follow the additional instructions below.

- Coat the shaft and bearings with grease or rust preventative compound to help seal out moisture.
- Periodically rotate the propeller and operate the dampers (if supplied) to keep a coating of grease on all internal bearing parts.
- Periodically inspect the fan to prevent damaging conditions.
- Block propeller to prevent natural rotation.
- Cover the unit with some type of weather cover to prevent moisture, corrosion, dirt or dust accumulation.



TUB

Installation

Damper Installation

- Place the damper inside the curb. Ensure the damper will open freely for the correct direction of the airflow.
- Secure to curb at the damper shelf by installing at least two sheet metal screws (#10 x 1/2") on each side of the damper, through the tray, with the screw head catching the flange on the damper. This will prevent the dampers from lifting.
- Drill a hole in the curb shelf for conduit needed for motor wiring.
- Operate the dampers manually to ensure the blades move freely. Dampers should be released from full open position to check for proper closing.

Note

An inlet basket guard is recommended. A basket guard prevents any large debris from being pulled into the fan and damaging the propeller. The Loren Cook basket guard is installed on top of the curb before the fan is installed.

Motor Installation

To prevent damage to the fan during shipping, motors 5 HP and larger, and extremely heavy motors (cast iron or severe duty) are shipped loose and must be field mounted.

The motor should be mounted so that the motor plate is between the fan shaft and motor shaft.

- Remove the motor plate mounting bolts and the motor plate.
- Remove the motor mounting bolts from the motor plate.
- Mount the motor to the motor plate aligning to the appropriate holes.
- Place the motor plate on the power assembly and reinstall the mounting bolts.

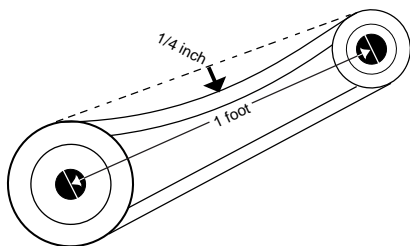

Figure 1

Belt and Pulley Installation

If your fan is a direct drive (model AUD), proceed to *Wiring Installation*.

Belt tension is determined by the sound of the belts when the fan is first started. The belts will produce a loud squeal, which dissipates after the fan is operating at full capacity. If belt tension is too tight or too loose, lost efficiency and damage can occur.

Do not change the pulley pitch diameter to change tension. The change will result in a different fan speed.

- Loosen the motor plate adjustment nuts on motor base and move motor plate in order that the belts can easily slip into the grooves on the pulleys. Never pry, roll, or force the belts over the rim of the pulley.
- Adjust the motor plate until proper tension is reached.

For proper tension, a deflection of approximately 1/4" per foot of center distance should be obtained by firmly pressing the belt. Refer to *Figure 1*.

- Lock the motor plate adjustment nuts in place.
- Ensure pulleys are properly aligned. Refer to *Figure 2*.

Tolerance

Center Distance	Maximum Gap
Up thru 12"	1/16"
12" up through 48"	1/8"
Over 48"	1/4"

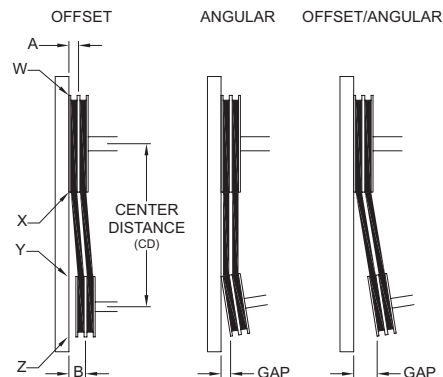

Figure 2

Pulley Alignment

Pulley alignment is adjusted by loosening the motor pulley setscrew and by moving the motor pulley on the motor shaft.

Figure 2 indicates where to measure the allowable gap for the drive alignment tolerance. All contact points (indicated by WXYZ) are to have a gap less than the tolerance shown in the table. When the pulleys are not the same width, the allowable gap must be adjusted by half of the difference in width. *Figure 3* illustrates using a carpenter's square to adjust the position of the motor pulley until the belt is parallel to the longer leg of the square.

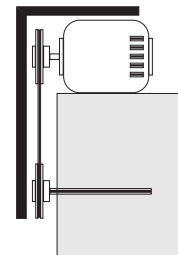

Figure 3

Wiring Installation

All wiring should be in accordance with local ordinances and the National Electrical Code, NFPA 70. Ensure the power supply (voltage, frequency, and current carrying capacity of wires) is in accordance with the motor nameplate. Refer to the *Wiring Diagrams*, on page 3.

Lock off all power sources before unit is wired to power source.

Leave enough slack in the wiring to allow for motor movement when adjusting belt tension. Some fractional motors have to be removed in order to make the connection with the terminal box at the end of the motor.

Personal Safety

Disconnect switches are recommended. Place the disconnect switch near the fan in order that the power can be swiftly cut off in case of an emergency, and in order that maintenance personnel are provided complete control of the power source.

Wiring Diagrams

Single Speed, Single Phase Motor

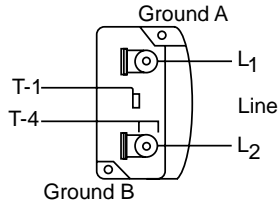

When ground is required, attach to ground A or B with no. 6 thread forming screw. To reverse, interchange T-1 and T-4.

2 Speed, 2 Winding, Single Phase Motor

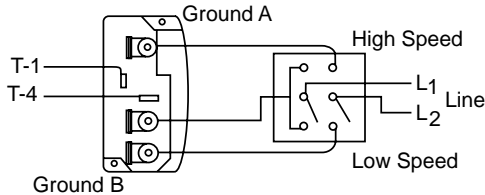

When ground required, attach to ground A or B with No. 6 thread forming screw. To reverse, interchange T-1 and T-4 leads.

Single Speed, Single Phase, Dual Voltage

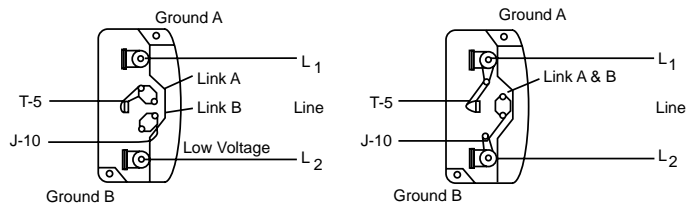

When ground required, attach to ground A or B with No. 6 thread forming screw. To reverse, interchange T-5 and J-10 leads.

Typical Damper Motor Schematic

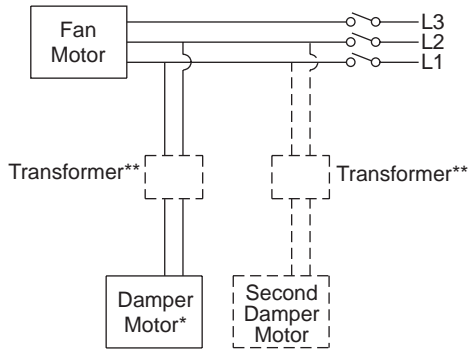

For 3 phase, damper motor voltage should be the same between L₁ and L₂. For single phase application, disregard L₃. *Damper motors may be available in 115, 230 and 460 volt models. The damper motor nameplate voltage should be verified prior to connection. ** A transformer may be provided in some installations to correct the damper motor voltage to the specified voltage.

Follow the wiring diagram in the disconnect switch and the wiring diagram provided with the motor. Correctly label the circuit on the main power box and always identify a closed switch to promote safety (i.e., red tape over a closed switch).

Fan Installation

The fan support (roof curb) should provide a level surface for installation. If the roof is pitched more than 1/2:12, a sloped curb must be used to correct for the incline. If the unit is installed on a non-level surface, the damper door pivot should be positioned perpendicular to the peak of the roof.

- Place fan over roof opening.
- Secure the fan with lag screws, anchor bolts, or other suitable fasteners.

Wiring Diagrams

3 Phase, 9 Lead Motor Y-Connection

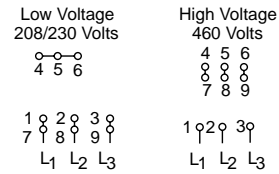

3 Phase, 9 Lead Motor Delta-Connection

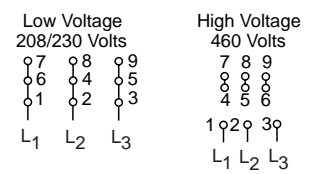

To reverse, interchange any 2 line leads.

2 Speed, 1 Winding, 3 Phase Motor

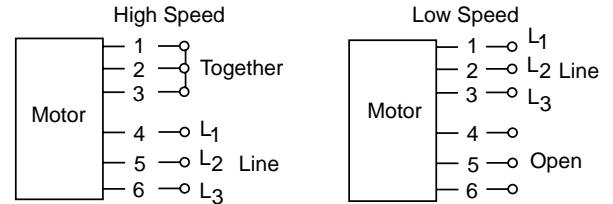

To reverse, interchange any 2 line leads. Motors require magnetic control.

2 Speed, 2 Winding, 3 Phase

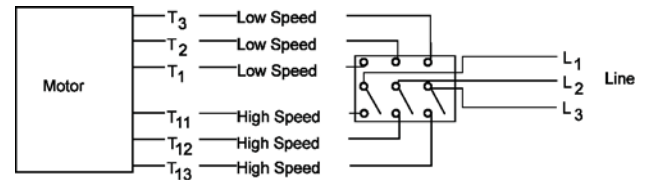

To reverse: High Speed-interchange leads T₁₁ and T₁₂. Low Speed-interchange leads T₁ and T₂. Both Speeds-interchange any 2 line leads.

Final Installation Steps

- Inspect fasteners and setscrews, particularly fan mounting and bearing fasteners, and tighten according to the recommended torque shown in the table on page 4, *Recommended Torque for Setscrews/Bolts*.
- Inspect for correct voltage with voltmeter.
- Ensure all accessories are installed.
- Test the fan to be sure the rotation is the same as indicated by the arrow marked **Rotation**.

Do not allow the fan to run in the wrong direction. This will overheat the motor and cause serious damage. For 3-phase motors, if the fan is running in the wrong direction, check the control switch. It is possible to interchange two leads at this location so that the fan is operating in the correct direction.

TUB / SUB / SUBH Additional Installation Steps

The damper actuator arms are safety bolted at the factory to prevent damage or personnel injury during handling and installation. The bolt must be removed for the damper actuator to operate correctly. Refer to *Figure 4*.

- Remove Bolt “A” from each of the damper arms.
- Be sure that linkage hook “B” is in contact with bolt “C” to prevent excessive load on the fusible link.

The damper arms will not operate unless this bolt is removed. This bolt should be replaced before any maintenance or repair work is started.

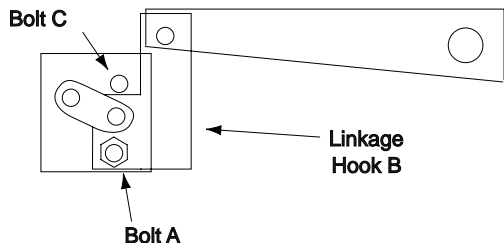

Figure 4 - SUBH Safety Bolt Removal

Operation

Pre-Start Checks

- Lock out all the primary and secondary power sources.
- Inspect fasteners and setscrews, particularly those used for mounting the unit, and tighten if necessary.
- Inspect belt tension and pulley alignment. (Remember, if belt tension is correct, a loud squeal occurs as the fan increases to full power.)
- Inspect motor wiring.
- Ensure the belt touches only the pulleys.
- Rotate the propeller to ensure it does not rub against the base.
- Ensure fan and ductwork are clean and free of debris.
- Test the fan to ensure the rotation of the propeller is the same as indicated by the rotation label.
- Close and secure all access doors.
- Restore power to unit.

Recommended Torque for Setscrews/Bolts (IN/LB.)

Setscrews				Hold Down Bolts	
Size	Key Hex Across Flats	Recommended Torque			
		Min.	Max.	Size	Wrench Torque
No.10	3/32"	28	33	3/8"-16	240
1/4"	1/8"	66	80	1/2"-13	600
5/16"	5/32"	126	156	5/8"-11	1200
3/8"	3/16"	228	275	3/4"-10	2100
7/16"	7/32"	348	384	7/8"-9	2040
1/2"	1/4"	504	600	1"-8	3000
5/8"	5/16"	1104	1200	1-1/8"-7	4200
3/4"	3/8"	1440	1800	1-1/4"-7	6000

Start Up

Turn the fan on. In variable speed units, set the fan to its lowest speed. Inspect for the following:

- Direction of rotation.
- Excessive vibration.
- Unusual noise.
- Bearing noise.
- Improper belt alignment or tension (listen for a continuous squealing noise).

- Improper motor amperage or voltage.

If a problem is discovered, immediately shut off the fan. Lock out all electrical power and check for the cause of the trouble. Refer to *Troubleshooting*, page 6.

Inspection

Inspection of the fan should be conducted at the first **30 minute, 8 hour and 24 hour** intervals of satisfactory operation. During the inspections, stop the fan and inspect as per the chart below.

30 Minute Interval

Inspect bolts, setscrews, and motor mounting bolts. Adjust and tighten as necessary.

8 Hour Interval

Inspect belt alignment and tension. Adjust and tighten as necessary.

24 Hour Interval

Inspect belt tension. Adjust and tighten as necessary.

Conditions Chart			
RPM	Temperature	Fan Status	Greasing Interval
100	Up to 120°F	Clean	6 to 12 months
500	Up to 150°F	Clean	2 to 6 months
1000	Up to 210°F	Clean	2 weeks to 2 months
1500	Over 210°F	Clean	Weekly
Any Speed	Up to 150°F	Dirty	1 week to 1 month
Any Speed	Over 150°F	Dirty	Daily to 2 weeks
Any Speed	Any Temperature	Very Dirty	Daily to 2 weeks
Any Speed	Any Temperature	Extreme Conditions	Daily to 2 weeks

Maintenance

Establish a schedule for inspecting all parts of the fan. The frequency of inspection depends on the operating conditions and location of the fan.

Inspect fans exhausting corrosive or contaminated air within the first month of operation. Fans exhausting contaminated air (airborne abrasives) should be inspected every three months. Clean the propeller and air inlets if material build-up is excessive. Excessive build-up can cause imbalance and failure of the propeller.

Regular inspections are recommended for fans exhausting non-contaminated air.

It is recommended the following inspections be conducted twice per year.

- Inspect bolts and setscrews for tightness. Tighten as necessary.
- Inspect belt wear and alignment. Replace worn belts with new belts and adjust alignment as needed. See *Belt and Pulley Installation*, page 2.
- Bearings should be inspected as recommended in the *Conditions Chart*.
- Inspect for cleanliness. Clean exterior surfaces only. Removing dust and grease on motor housing assures proper motor cooling.

Lubricants

Loren Cook Company uses petroleum lubricant in a lithium base conforming to NLGI grade 2 consistency. Other

grades of grease should not be used unless the bearings and lines have been flushed clean. If another grade of grease is used, it should be lithium-based.

A NLGI grade 2 grease is a light viscosity, low-torque, rust-inhibiting lubricant that is water resistant. Its temperature range is from -30°F to +200°F and capable of intermittent highs of +250°F.

Motor Bearings

Motor bearings are pre-lubricated and sealed. Under normal conditions they will not require further maintenance for a period of ten years. However, it is advisable to have your maintenance department remove and disassemble the motor, and lubricate the bearings after three years of operation in excessive heat and or in a contaminated airstream consisting of airborne abrasives.

Fan Bearings

Fan bearings are lubricated through a grease connector and should be lubricated by the schedule, *Conditions Chart*, on page 4.

For best results, lubricate the bearing while the fan is rotating. Slowly pump grease into the bearing until a slight bead forms around the bearing seals. Excessive grease can burst seals thus reduce bearing life.

In the event the bearing cannot be seen, use no more than three injections with a hand-operated grease gun.

Motor Services

Should the motor prove defective within a one-year period, contact your local Loren Cook representative or your nearest authorized electric motor service representative.

Changing Shaft Speed

All belt driven propeller roof fans with motors up to and including 5HP are equipped with variable pitch pulleys. To change the fan speed, perform the following:

- Loosen setscrew on driver (motor) pulley and remove key, if equipped.
- Turn the pulley rim to open or close the groove facing. If the pulley has multiple grooves, all must be adjusted to the same width.
- After adjustment, inspect for proper belt tension.

Speed Reduction

Open the pulley in order that the belt rides deeper in the groove (smaller pitch diameter).

Speed Increase

Close the pulley in order that the belt rides higher in the groove (larger pitch diameter). Ensure that the RPM limits of the fan and the horsepower limits of the motor are maintained.

Maximum RPM

TUB, SUB, SUBH Size	Maximum RPM
20	2633
24	1993
30	1605
36	1314
42	1106
48	973
54	888
60	783
72	616

AUB	Maximum RPM
24	1585
30	1180
36	1015
42	935
48	845

EUB	Maximum RPM
24	1650
30	1305
36	1305
42	1200
48	1150
54	900
60	870
72	688

Maximum RPM

LXUL Size	Maximum RPM
20	1270
24	1110
30	930
36	720
42	600
48	508
54	478
60	450

LXUM	Maximum RPM
20	1460
24	1400
30	1170
36	860
42	718
48	598
54	522
60	476

LEU	Maximum RPM
20	1675
24	1650
30	1350
36	1310
42	1210
48	1214
54	946
60	854

Pulley and Belt Replacement

- Clean the motor and fan shafts.
 - Loosen the motor plate mounting bolts to relieve the belt tension. Remove the belt.
 - Loosen the pulley setscrews and remove the pulleys from the shaft.
- If excessive force is required to remove the pulleys, a three-jaw puller can be used. This tool, however, can easily warp a pulley. If the puller is used, inspect the trueness of the pulley after it is removed from the shaft. The pulley will need replacement if it is more than 0.020 inch out of true.
- Clean the bores of the pulleys and place a light coat of oil on the bores.
 - Remove grease, rust and burrs from the shaft.
 - Place fan pulley on the fan shaft and the motor pulley on the motor shaft. Damage to the pulleys can occur when excessive force is used in placing the pulleys on their respective shafts.
 - After the pulleys have been correctly placed back onto their shafts, tighten the pulley setscrews.
 - Install the belts on the pulleys. Align and adjust the belts to the proper tension as described in *Belt and Pulley Installation*, page 2.

Bearing Replacement

The fan bearings are pillow block ball bearings.

- Remove the wind band and damper assembly to gain access to the fan.
- Loosen the motor plate mounting bolts and remove the drive belts.
- Remove the propeller from the shaft.
- Remove the bearing cover. Remove the four (4) bearing hold-down bolts and then remove the shaft, bearings, and driven sheave from the unit as an assembly.
- Measure and record the location of the bearings and sheave on the shaft. This will aid the reassembly.
- Remove the anti-corrosion coating from the shaft with a suitable degreaser and then remove the pulley from the shaft. An emery cloth or file may be needed to remove imperfections in the shaft left by the setscrews.

- g. Remove the bearing from the shaft using a bearing puller.
- h. Clean the shaft and bearing bores thoroughly.
- i. Place the bearings into position making sure they are not on a worn section of the shaft. Tapping the inner ring face with a soft driver may be required. Tighten the setscrews on the lower bearing.
- j. Install the pulley in the correct location on the shaft. Secure the bearing hold-down bolts, but do not fully tighten.
- k. Align the setscrews on the top bearing with those on the lower bearing. Tighten one of them.
- l. Rotate the shaft to allow the bearing outer rings to find their center of free movement. If your fan is supplied with a lube line, attach it to the grease connection.
- m. Install the propeller on the shaft and adjust bearing position to center the propeller in the opening.
- n. Tighten hold-down bolts to proper torque. Refer to the *Torque Chart* on page 4.
- o. Turn the shaft by hand. Resistance should be the same as it was before hold-down bolts were fully tightened.
- p. Tighten bearing setscrews to specified torque.
- r. Reassembly the fan.

After 24 hours of continuous operation, tighten the setscrews to the appropriate torque. This assures the full locking of the inner race to the shaft. Ensure the socket key or driver is in good condition with no rounded corners. The key should be fully engaged in the setscrew and held squarely to prevent the rounding out of the setscrew socket when applying maximum torque.

Propeller and Shaft Replacement Precautions

- If the shaft is dropped and bent, it may cause unbalanced operation of the fan.
- When handling the propeller separately from the shaft, place a support through the hub for lifting, making sure not to injure the finished bore of the propeller.
- Never allow the propeller to rest its entire weight on the blades. The propeller and shaft can be lifted by slings around the shaft on each side of the propeller so the propeller is supported by its hub.
- If using a chain to lift the propeller, make sure there is sufficient padding on the shaft and propeller. This prevents the scoring of the shaft or injury to the propeller. The chain or cable should be spread with timbers, or braced by some other method to prevent damage to the propeller side plates.

Troubleshooting

Problem and Potential Cause
<p>Low Capacity or Pressure</p> <ul style="list-style-type: none"> •Incorrect direction of rotation. Make sure the fan rotates in same direction as the arrows on the motor or belt drive assembly. •Poor fan inlet conditions. There should be a straight clear duct at the inlet. •Improper propeller alignment.
<p>Excessive Vibration and Noise</p> <ul style="list-style-type: none"> •Damaged or unbalanced propeller. •Belts too loose; worn or oily belts. •Speed too high. •Incorrect direction of rotation. Make sure the fan rotates in same direction as the arrows on the motor or belt drive assembly. •Bearings need lubrication or replacement. •Fan surge.
<p>Overheated Motor</p> <ul style="list-style-type: none"> •Motor improperly wired. •Incorrect direction of rotation. Make sure the fan rotates in same direction as the arrows on the motor or belt drive assembly. •Cooling air diverted or blocked. •Improper inlet clearance. •Incorrect fan RPMs. •Incorrect voltage.
<p>Overheated Bearings</p> <ul style="list-style-type: none"> •Improper bearing lubrication •Excessive belt tension.

AUD/TUD Parts List

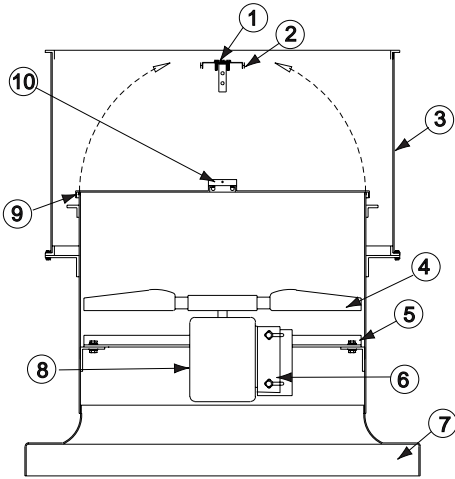

Parts No.	Description	
	AUD (Sizes 24 - 48)	TUD (Sizes 20 - 60)
1	Damper Stop	Damper Stop
2	Rubber Bumper(2)	Rubber Bumper(2)
3	Wind Band	Wind Band
4	Cast Aluminum Propeller	Welded Steel Propeller
5	Power Assembly	Power Assembly
6	Motor Plate	Motor Plate
7	Lower Drum Assembly	Lower Drum Assembly
8	Motor	Motor
9	Damper Rubber Extrusion (2)	Damper Rubber Extrusion (2)
10	Damper Assembly	Damper Assembly

EUB/AUB Parts List

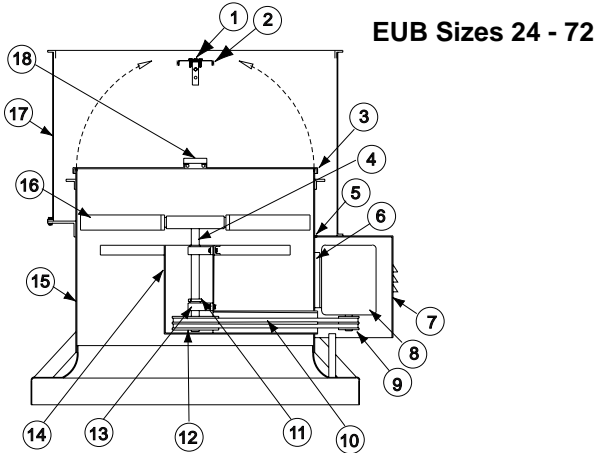

Parts No.	Description	
	EUB (Sizes 24 - 72)	AUB (Sizes 24 - 48)
1	Damper Backstop	Damper Backstop
2	Rubber Bumper (2)	Rubber Bumper (2)
3	Damper Rubber Extrusion (2)	Damper Rubber Extrusion (2)
4	Shaft	Shaft
5	Weather Cover Rubber Extrusion	Weather Cover Rubber Extrusion
6	Motor Plate	Motor Plate
7	Weather Cover	Weather Cover
8	Motor	Motor
9	Driver Sheave	Driver Sheave
10	Belt Set	Belt Set
11	Split Locking Collar	Split Locking Collar
12	Driven Sheave	Driven Sheave
13	Bearings (2)	Bearings (2)
14	Bearing Cover	Bearing Cover
15	Lower Drum Assembly	Lower Drum Assembly
16	Extruded Aluminum	Cast Aluminum
17	Wind Band Assembly	Wind Band Assembly
18	Damper Assembly	Damper Assembly

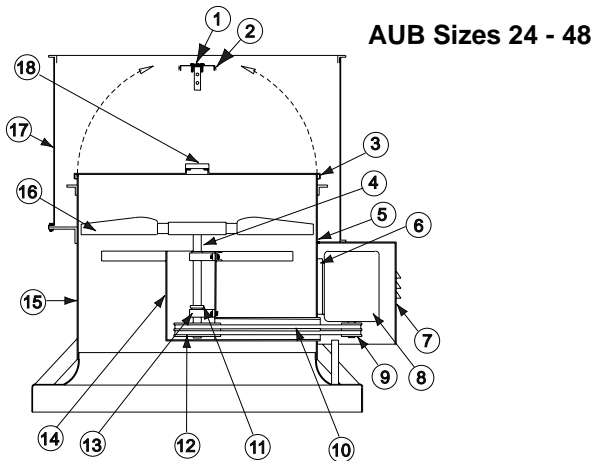

SUB/SUBH/TUB Parts List

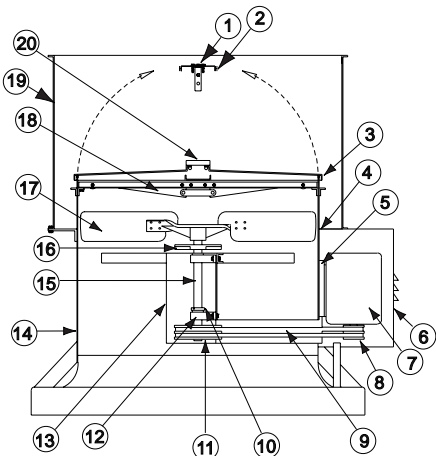

Part No.	Description	
	SUB/TUB (Sizes 24 - 72)	SUBH (Sizes 24 - 72)
1	Damper Backstop	Damper Backstop
2	Rubber Bumper (2)	Rubber Bumper (2)
3	Damper Rubber Extrusion	Damper Rubber Extrusion
4	Weather Cover Rubber Extrusion	Weather Cover Rubber Extrusion
5	Motor Plate	Motor Plate
6	Weather Cover	Weather Cover
7	Motor	Motor
8	Driver Sheave	Driver Sheave
9	Belt Set	Belt Set
10	Split Locking Collar	Split Locking Collar
11	Driven Sheave	Driven Sheave
12	Bearings (2)	Bearings (2)
13	Bearing Cover	Bearing Cover
14	Lower Drum Assembly	Lower Drum Assembly
15	Shaft	Shaft
16	Heat Slinger (optional)	Heat Slinger
17	Steel Propeller	Steel Propeller
18	Spring Loaded Damper	Spring Loaded Damper
19	Wind Band Assembly	Wind Band Assembly
20	Damper Assembly	Damper Assembly

LXUL/LXUM Parts List

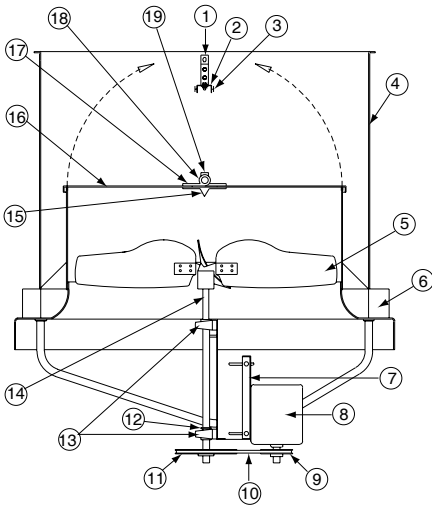

LEU Parts List

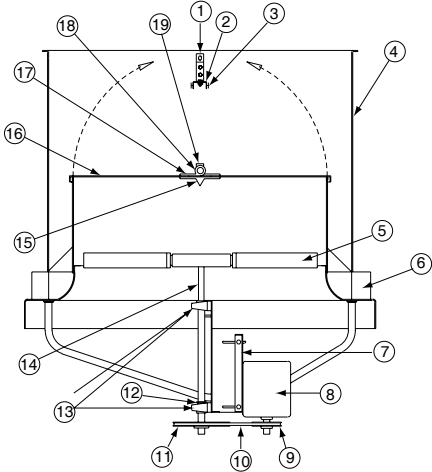

Part No.	LXUL/LXUM Description			
	Size 20-24	Size 30-36	Size 42-54	Size 60
1	Damper Stop Bracket (2)	Damper Stop Bracket (2)	Damper Stop Bracket (2)	Damper Stop Bracket (2)
2	Damper Stop Channel	Damper Stop Channel	Damper Stop Channel	Damper Stop Channel
3	Damper Bumper (2)	Damper Bumper (2)	Damper Bumper (2)	Damper Bumper (2)
4	Windband	Windband	Windband	Windband
5	X-Stream Propeller	X-Stream Propeller	X-Stream Propeller	X-Stream Propeller
6	Base Weldment	Base Weldment	Base Weldment	Base Weldment
7	Motor Plate	Motor Plate	Motor Plate	Motor Plate
8	Motor	Motor	Motor	Motor
9	Drive Sheave	Drive Sheave	Drive Sheave	Drive Sheave
10	Belt	Belt	Belt	Belt
11	Driven Sheave	Driven Sheave	Driven Sheave	Driven Sheave
12	-	-	Locking Collar	Locking Collar
13	3/4" Bore Bearing (2)	1" Bore Bearing (2)	1-3/16" Bore Bearing (2)	1-7/16" Bore Bearing (2)
14	Shaft	Shaft	Shaft	Shaft
15	Rain Gutter	Rain Gutter	Rain Gutter	Rain Gutter
16	Damper Door (2)	Damper Door (2)	Damper Door (2)	Damper Door (2)
17	Damper Hinge (4)	Damper Hinge (4)	Damper Hinge (8)	Damper Hinge (8)
18	Damper Pivot Rod	Damper Pivot Rod	Damper Pivot Rod	Damper Pivot Rod
19	Damper Pivot Bracket	Damper Pivot Bracket	Damper Pivot Bracket	Damper Pivot Bracket

Part No.	LEU Description		
	Size 20-36	Size 42-54	Size 60
1	Damper Stop Bracket (2)	Damper Stop Bracket (2)	Damper Stop Bracket (2)
2	Damper Stop Channel	Damper Stop Channel	Damper Stop Channel
3	Damper Bumper (2)	Damper Bumper (2)	Damper Bumper (2)
4	Windband	Windband	Windband
5	Extruded Propeller	Extruded Propeller	Extruded Propeller
6	Base Weldment	Base Weldment	Base Weldment
7	Motor Plate	Motor Plate	Motor Plate
8	Motor	Motor	Motor
9	Drive Sheave	Drive Sheave	Drive Sheave
10	Belt	Belt	Belt
11	Driven Sheave	Driven Sheave	Driven Sheave
12	-	Locking Collar	Locking Collar
13	1" Bore Bearing (2)	1-3/16" Bore Bearing (2)	1-7/16" Bore Bearing (2)
14	Shaft	Shaft	Shaft
15	Rain Gutter	Rain Gutter	Rain Gutter
16	Damper Door (2)	Damper Door (2)	Damper Door (2)
17	Damper Hinge (4)	Damper Hinge (8)	Damper Hinge (8)
18	Damper Pivot Rod	Damper Pivot Rod	Damper Pivot Rod
19	Damper Pivot Brackets (2)	Damper Pivot Brackets (2)	Damper Pivot Brackets (2)

Limited Warranty

Loren Cook Company warrants that your Loren Cook fan was manufactured free of defects in materials and workmanship, to the extent stated herein. For a period of one (1) year after date of shipment, we will replace any parts found to be defective without charge, except for shipping costs which will be paid by you. This warranty is granted only to the original purchaser placing the fan in service. This warranty is void if the fan or any part thereof has been altered or modified from its original design or has been abused, misused, damaged or is in worn condition or if the fan has been used other than for the uses described in the company manual. This warranty does not cover defects resulting from normal wear and tear. To make a warranty claim, notify Loren Cook Company, General Offices, 2015 East Dale Street, Springfield, Missouri 65803-4637, explaining in writing, in detail, your complaint and referring to the specific model and serial numbers of your fan. Upon receipt by Loren Cook Company of your written complaint, you will be notified, within thirty (30) days of our receipt of your complaint, in writing, as to the manner in which your claim will be handled. If you are entitled to warranty relief, a warranty adjustment will be completed within sixty (60) business days of the receipt of your written complaint by Loren Cook Company. This warranty gives only the original purchaser placing the fan in service specifically the right. You may have other legal rights which vary from state to state.

LOREN COOK COMPANY

Corporate Offices: 2015 E. Dale Street Springfield, MO 65803 417.869.6474
lorencook.com