



# COOK

# CAF DW

DATE: \_\_\_\_\_  
 PROJECT: \_\_\_\_\_  
 LOCATION: \_\_\_\_\_



**Centrifugal Airfoil Blower**  
**Clockwise Top Angular Down**  
**Arrangement 3**  
**Low Profile**  
**Class III**

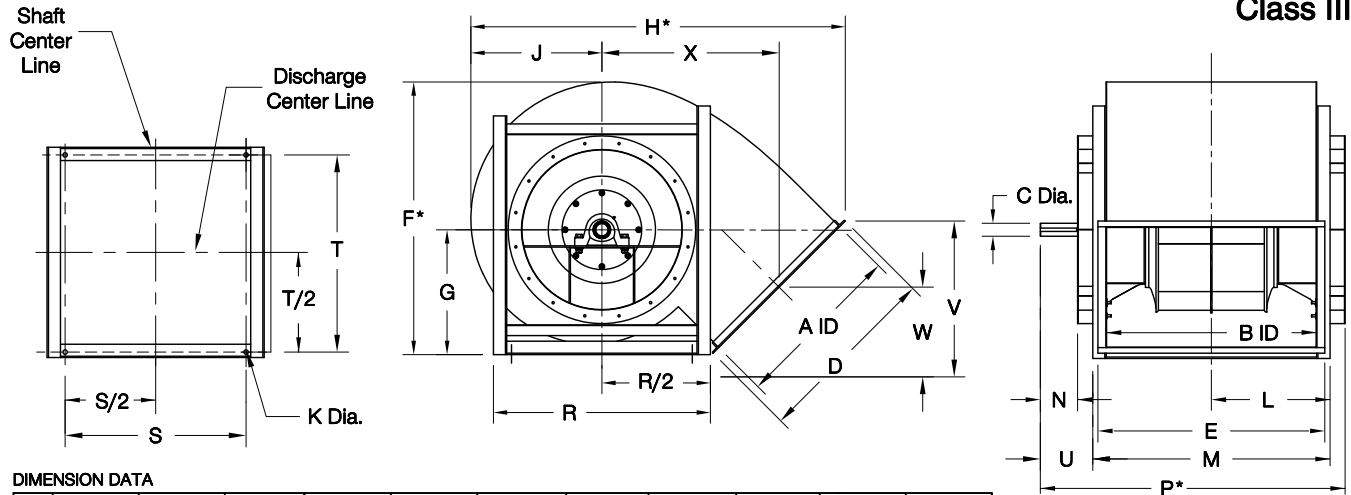

**DIMENSION DATA**

Size	A	B	C	D	E	F	G	H	J	K	L
120	12-1/8	17-11/16	1-11/16	14-3/8	19-13/16	22-3/4	11-11/16	30-13/16	9-13/16	15/16	11-15/16
135	13-5/8	19-15/16	1-15/16	15-7/8	22-1/16	24-13/16	12-3/8	33-15/16	11-1/16	15/16	13-1/16
150	15-1/4	22	1-15/16	17-1/2	24-1/8	27	13-3/16	37-1/16	12-5/16	15/16	14-1/16
165	16-15/16	24	2-3/16	19-3/16	26-1/8	29-7/16	14-3/16	40-3/8	13-1/2	15/16	15-1/16
180	18-1/2	26-1/16	2-3/16	20-3/4	28-3/16	32-1/16	15-7/16	43-15/16	14-3/4	15/16	16-1/8
195	19-1/2	28-7/16	2-3/16	23-3/4	32-9/16	34-1/2	16-1/2	47-3/4	15-15/16	15/16	17-5/16
210	21-5/8	30-3/8	2-3/16	25-3/4	34-1/2	37-3/8	18	51-1/4	17-3/16	15/16	18-1/4
225	23-3/16	32-1/2	2-3/16	27-7/16	36-11/16	39-5/8	18-7/8	54-7/16	18-7/16	15/16	19-5/16
245	25-1/2	35-1/16	2-7/16	29-3/4	39-1/4	42-7/8	20-5/16	58-7/8	20-1/16	1-1/16	21-5/8
270	27-1/2	39-7/16	2-7/16	31-3/4	43-5/8	46-13/16	21-15/16	64	22-1/16	1-1/16	23-13/16
300	31-3/16	43	2-7/16	35-7/16	47-3/16	50-7/8	23-1/4	70-9/16	24-1/2	1-1/16	25-9/16
330	34-1/2	47-1/16	2-7/16	38-7/8	51-5/16	55-9/16	25-1/8	77	27	1-1/16	28-5/8
365	38-11/16	52-3/16	2-15/16	44-1/16	57-7/16	62-5/16	28-11/16	85-11/16	29-7/8	1-1/16	31-3/16
402	41-3/4	57-13/16	3-7/16	47-1/8	63-1/16	66-7/8	29-13/16	93-3/16	32-7/8	1-1/16	35
445	45-15/16	64-1/4	3-7/16	51-5/16	69-9/16	73-3/4	32-3/4	102-5/16	36-3/8	1-1/16	38-1/4
490	51	70-1/8	3-15/16	56-3/8	75-7/16	81-1/8	35-15/16	113-3/16	40-1/16	1-1/16	43-3/16
540	55-3/4	77-15/16	4-7/16	61-1/4	83-3/8	89-5/16	39-1/2	122	44-3/16	1-3/16	47-1/8
600	62-3/16	86-1/4	4-15/16	67-3/4	91-11/16	99-1/8	43-13/16	134-7/8	49-1/16	1-3/16	51-5/16

\*F, H, and P dimensions are overall dimensions.

Size	M	N	P	R	S	T	U	V	W	X	Approx. Wt
120	23-13/16	6-1/2	31-7/16	19-1/16	14-1/2	20-1/16	7-9/16	10-3/16	5-1/8	15-7/8	261
135	26-1/16	6-1/2	33-11/16	20-13/16	16-1/4	22-5/16	7-9/16	11-1/4	5-5/8	17-1/4	302
150	28-1/8	6-1/2	35-3/4	22-5/16	17-3/4	24-3/8	7-9/16	12-3/8	6-3/16	18-9/16	331
165	30-1/8	6-1/2	38-5/16	24-1/16	19-1/2	26-3/8	8-1/16	13-9/16	6-3/4	20-1/16	401
180	32-3/16	6-1/2	40-3/8	25-9/16	21	28-7/16	8-1/16	14-11/16	7-5/16	21-7/8	424
195	34-9/16	6-1/2	42-3/4	27-5/16	22-1/4	31-5/16	8-1/16	16-7/8	8-7/16	23-3/8	521
210	36-1/2	7	45-3/16	28-13/16	23-3/4	33-1/4	8-9/16	18-3/8	9-3/16	24-15/16	575
225	38-5/8	7	47-5/16	30-9/16	25-1/2	35-3/8	8-9/16	19-1/2	9-3/4	26-5/16	642
245	43-3/16	7	50-13/16	32-15/16	27-1/8	38-9/16	7-9/16	21-1/8	10-9/16	28-5/16	796
270	47-9/16	7-1/8	55-5/16	35-11/16	29-7/8	42-15/16	7-11/16	23-3/8	12-1/8	30-11/16	919
300	51-1/8	7-1/8	58-7/8	38-11/16	32-7/8	46-1/2	7-3/4	25-1/8	12-9/16	33-1/2	1139
330	57-1/4	7-1/8	64	42-1/4	35-1/4	51-3/4	6-3/4	27-1/2	13-3/4	36-1/4	1447
365	62-3/8	7-5/8	70-1/8	46	39	56-7/8	7-3/4	31-3/16	15-9/16	40-5/16	1822
402	70	10-1/8	80-3/4	50-9/16	42	63-1/2	10-3/4	33-3/8	16-11/16	43-11/16	2407
445	76-1/2	10-1/8	87-1/4	54-13/16	46-1/4	70	10-3/4	37-5/8	19	47-13/16	2984
490	86-3/8	13-1/2	98-1/2	60	50	76-7/8	12-1/8	40-11/16	19-15/16	53-3/16	3621
540	94-5/16	15-3/4	110-11/16	65	55	84-13/16	16-3/8	46-5/16	24-5/8	56-3/16	4883
600	102-5/8	15-7/8	118-5/8	71	61	93-1/8	16	51-9/16	27-5/8	61-7/8	5866

ALL DIMENSIONS IN INCHES. ALL WEIGHTS IN POUNDS, LESS MOTOR AND DRIVES.