



COOK

CF-4 SWSI

DATE: _____
 PROJECT: _____
 LOCATION: _____



Flat Blade Centrifugal Blower
 Arrangement 1

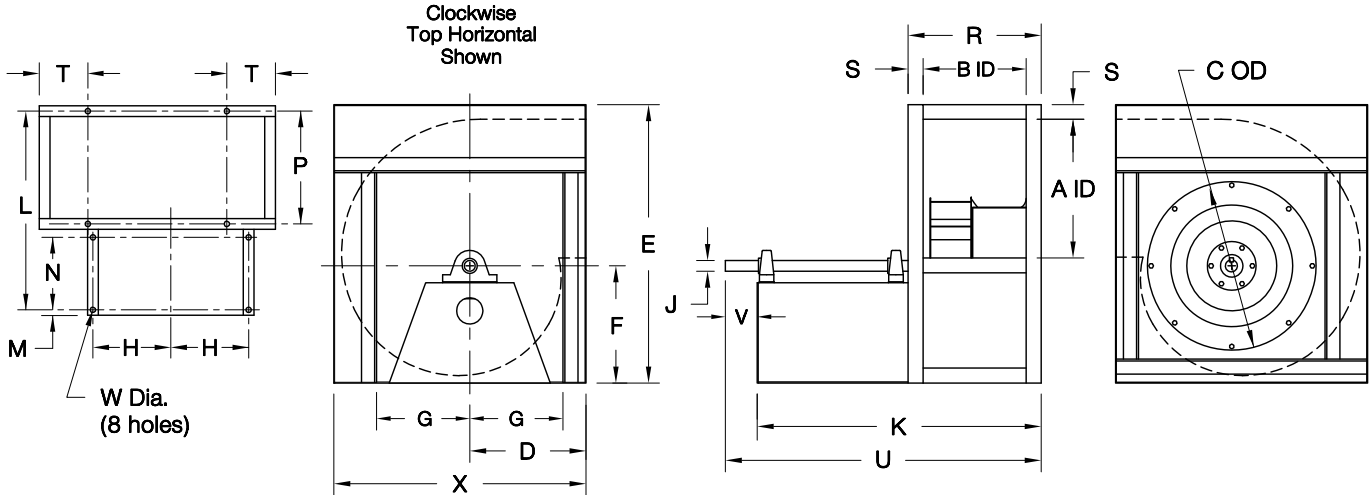

DIMENSION DATA

Size	A	B	C	D	E	F	G	H	J			K	L	M	N
									Class I	Class II	Class III				
120	13-1/8	9-3/16	16-1/8	10-3/8	25-3/4	10-3/4	9-3/16	8-7/16	1-3/16	1-7/16	1-7/16	30-13/16	28-15/16	1	15-1/8
135	14-3/4	10-5/16	17-5/8	11-5/8	28-3/4	12	9-15/16	9-3/16	1-3/16	1-7/16	1-7/16	31-15/16	30-1/16	1	15-1/8
150	16-7/16	11-7/16	19-1/8	12-7/8	31-5/8	13-1/4	10-11/16	9-15/16	1-3/16	1-7/16	1-7/16	33-1/16	31-3/16	1	15-1/8
165	18-1/16	12-5/8	21-3/16	14-1/4	34-3/8	14-3/8	11-11/16	10-15/16	1-3/16	1-7/16	1-7/16	34-1/4	32-3/8	1	15-1/8
180	19-11/16	13-3/4	22-11/16	15-1/2	37-1/8	15-5/8	12-7/16	11-11/16	1-3/16	1-7/16	1-11/16	37-7/8	36	1	17-5/8
195	21-5/16	14-15/16	24-3/16	16-3/4	40	16-3/4	13-3/16	12-7/16	1-3/16	1-7/16	1-11/16	39-1/16	37-3/16	1	17-5/8
210	23	16-1/16	25-15/16	18-1/8	42-7/8	18	14-1/16	13-5/16	1-7/16	1-11/16	1-15/16	42-3/16	40-5/16	1	19-9/16
225	24-5/8	17-3/16	27-7/16	19-3/8	45-3/4	19-1/4	14-13/16	14-1/16	1-7/16	1-11/16	1-15/16	43-5/16	41-7/16	1	19-9/16
245	26-13/16	18-3/4	29-7/16	21-1/8	49-1/2	20-7/8	15-13/16	15-1/16	1-11/16	1-15/16	2-7/16	45-3/8	43-1/2	1	20-1/8
270	29-9/16	20-5/8	31-15/16	23-1/4	54-3/4	23-3/8	17-3/16	16-7/16	1-11/16	1-15/16	2-7/16	47-1/4	45-3/8	1	20-1/8
300	32-13/16	22-15/16	34-15/16	25-7/8	60	25-3/8	18-11/16	17-15/16	1-15/16	2-3/16	2-7/16	51-13/16	49-15/16	1	22-3/8
330	36-1/8	25-1/4	37-15/16	28-3/8	65-3/4	27-7/8	20-3/16	19-7/16	1-15/16	2-3/16	2-7/16	54-1/8	52-1/4	1	22-3/8
365	39-15/16	27-7/8	41-7/16	31-3/8	72-3/8	30-5/8	22-7/16	21-11/16	2-3/16	2-7/16	2-15/16	59	57-1/8	1	24-5/8
402	44-1/16	30-3/4	45-3/16	34-5/8	80-3/8	33-5/8	24-3/8	23-3/8	2-3/16	2-7/16	2-15/16	62-15/16	60-7/16	1-1/4	23-13/16
445	48-11/16	34	49-7/16	38-1/4	88-1/2	37-1/8	26-1/2	25-1/2	2-7/16	2-15/16	3-7/16	66-15/16	64-7/16	1-1/4	24-9/16
490	53-5/8	37-7/16	55	42-1/4	97	40-3/4	29-1/4	28-1/4	2-7/16	2-15/16	3-7/16	70-3/8	67-7/8	1-1/4	24-9/16
540	59-1/16	41-1/4	60	46-1/2	106-5/8	44-7/8	31-3/4	30-3/4	2-15/16	3-7/16	3-15/16	74-1/4	71-3/4	1-1/4	24-9/16
600	65-5/8	45-13/16	66	51-5/8	118	49-3/4	34-3/4	33-3/4	2-15/16	3-7/16	3-15/16	78-13/16	76-5/16	1-1/4	24-9/16

Size	P	R	S	T	U	V	W	X	Ship Wt*
120	11-7/16	13-3/16	2	4	34-13/16	4	11/16	22-3/4	222
135	12-9/16	14-5/16	2	4	35-15/16	4	11/16	25-1/2	280
150	13-11/16	15-7/16	2	4	37-1/16	4	11/16	28-1/8	341
165	14-7/8	16-5/8	2	4	38-1/4	4	11/16	30-7/8	407
180	16	17-3/4	2	4	42-1/8	4-1/4	11/16	33-5/8	476
195	17-3/16	18-15/16	2	4	43-5/16	4-1/4	11/16	36-1/4	549
210	18-5/16	20-1/16	2	5	46-7/16	4-1/4	13/16	39-1/8	630
225	19-7/16	21-3/16	2	5	47-9/16	4-1/4	13/16	41-3/4	711
245	21	22-3/4	2	5	50-9/16	5-1/4	13/16	45-3/8	825
270	22-7/8	24-5/8	2	5	52-7/16	5-1/4	13/16	49-7/8	978
300	25-3/16	26-15/16	2	5	57-11/16	5-7/8	13/16	55-3/8	1175
330	27-1/2	29-1/4	2	5	60	5-7/8	13/16	60-3/4	1387
365	30-1/8	31-7/8	2	5	64-7/8	5-7/8	13/16	67	1655
402	34-1/4	36-3/4	3	6	68-1/16	5-7/8	1-1/16	73-7/8	1953
445	37-1/2	40	3	6	73-1/16	6-3/8	1-1/16	81-1/2	2336
490	40-15/16	43-7/16	3	6	76-1/2	6-3/8	1-1/16	89-3/4	2771
540	44-3/4	47-1/4	3	6	81-5/8	7-1/2	1-1/16	98-3/4	3350
600	49-5/16	51-13/16	3	8	86-3/16	7-1/2	1-1/16	109-5/8	4045

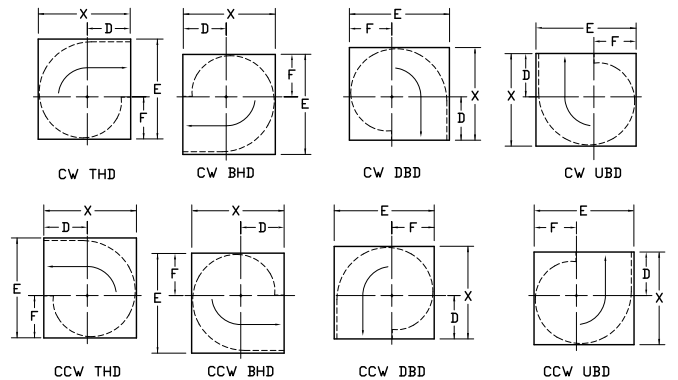

ALL DIMENSIONS IN INCHES. WEIGHTS IN LBS., LESS MOTOR.
 * BASED ON CLASS I CONSTRUCTION.