



# COOK

# TCNU-B

DATE: \_\_\_\_\_

PROJECT: \_\_\_\_\_

LOCATION: \_\_\_\_\_

**Tubular Centrifugal Upblast  
Roof Mounted / Exhaust  
Belt Drive****DIMENSION DATA**

Size	A	B	C	D	E	F	G	H	J	T Sq.	Max. Mtr. Frame
60-100	22	14-7/8	19	16	3	33-1/4	18	39-7/8	13	24	143T
120	23	15-15/16	21	18	3	35	18	41-15/16	13	24	145T
135	24-1/2	18	24	21	3	39-1/8	18	45-1/2	13	28	145T
150	27	19-15/16	27	24	3	41-3/4	22	49-15/16	16-3/4	30	145T
165	28-1/2	20-7/8	29	26	3	43-3/16	22	52-3/8	16-3/4	30	182T
180	31	22-1/16	31	28	3	47-9/16	22	56-1/16	16-3/4	36	182T
195	33-1/4	24-7/16	34	31	3	50-7/16	22	60-11/16	16-3/4	38	182T
210	34-1/2	26-9/16	37	34	3	54-1/4	22	64-1/16	16-3/4	42	182T
225	35-1/2	27-1/4	40-1/4	36	3	59	25	65-3/4	18	42	184T
245	41	29-5/8	44-1/4	40	3	64-5/16	25	73-5/8	18	48	213T
270	46-1/2	32-1/2	48-1/4	44	3	71-11/16	30	82	21	54	213T
300	48-1/4	35-5/16	52-1/4	48	3	73-15/16	30	86-9/16	21	54	215T
330	52	37-3/16	56-1/4	52	3	79-3/16	30	92-3/16	21	60	215T
365	54	38-9/16	58-1/4	54	3	81-3/8	30	95-9/16	21	62	215T
402	59-1/2	43	64-1/4	60	3	93-3/8	40	105-1/2	26	72	215T
445	66	46-1/16	70-1/4	66	3	98-11/16	40	115-1/16	26	76	254T
490	72-1/2	51-3/8	77-1/4	73	4	106-1/2	40	127-7/8	26	84	254T

ALL DIMENSIONS IN INCHES. WEIGHT IN LBS., LESS MOTOR.

**STANDARD CONSTRUCTION FEATURES:**

All aluminum wheel - Minimum 12 gauge  
 steelhousing with standard inspection door -  
 Lorenized baked powder paint finish - Welded  
 steel construction - Regreasable bearings in  
 cast housing rated at 400,000 hours average  
 life - Extended lube lines - Adjustable pitch  
 drives through 5 hp - All fans factory adjusted  
 to specified fan RPM.

**ACCESSORIES**

1. DISCONNECT SWITCH
2. OUTLET GUARD
3. ACCESS DOOR
4. ALUMINUM WHEEL

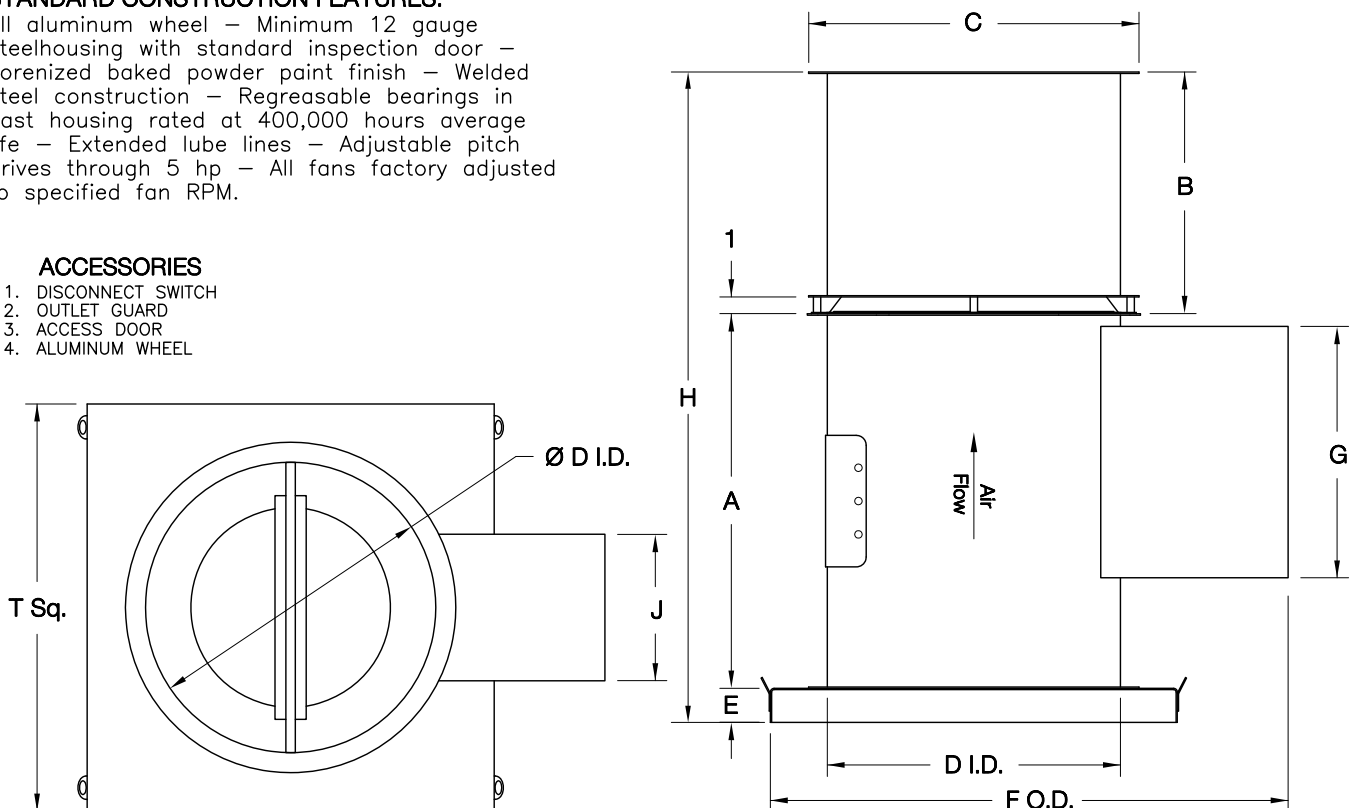

CV020R00