



COOK

APB

DATE: _____

PROJECT: _____

LOCATION: _____



Axia-Pac Wall Exhaust Ventilator Cast Aluminum Propeller Belt Drive

DIMENSION DATA

SIZE	A	B*	C	D*	WALL OPENING	WALL HOUSING GAUGE	SHIPPING WEIGHT
24	33-1/2	31	27-1/2	37-3/8	31-1/4	18 GA.	220
30	39-1/2	37	33-1/2	38	37-1/4	18 GA.	275
36	45-1/2	43	39-1/2	39-1/2	43-1/4	18 GA.	345
42	51-1/2	49-1/16	45-1/2	40-7/8	49-5/16	16 GA.	440
48	57-1/2	55-1/16	51-1/2	50-7/8	55-5/16	16 GA.	550

Note: Correct propeller rotation is CCW when viewing from inlet side.

ALL DIMENSIONS IN INCHES. SHIP WEIGHTS IN LBS., LESS MOTOR.
*B & D DIMENSIONS ARE TO OUTSIDE OF FASTENERS ON WALL HOUSING.

STANDARD CONSTRUCTION FEATURES:

Cast aluminum propeller – Spun steel Venturi/wall base – Heavy duty steel power assembly – Welded wall base corners – Galvanized steel wall housing – Galvanized steel exhaust shutter – 1/2" mesh galvanized screen on inlet – Regreasable bearings rated at 200,000 hours average life – Adjustable pitch drives through 3 hp motor – Propellers are statically and dynamically balanced – Corrosion resistant fasteners – Static resistant belts – All fans factory adjusted to specified fan RPM.

ACCESSORIES

1. DISCONNECT SWITCH
2. MOTORIZED SHUTTER
3. EISEN-HEISS COATING
4. EPOXY COATING
5. ALL ALUMINUM EXHAUST SHUTTER
6. ALUMINUM CONSTRUCTION
7. SPECIAL

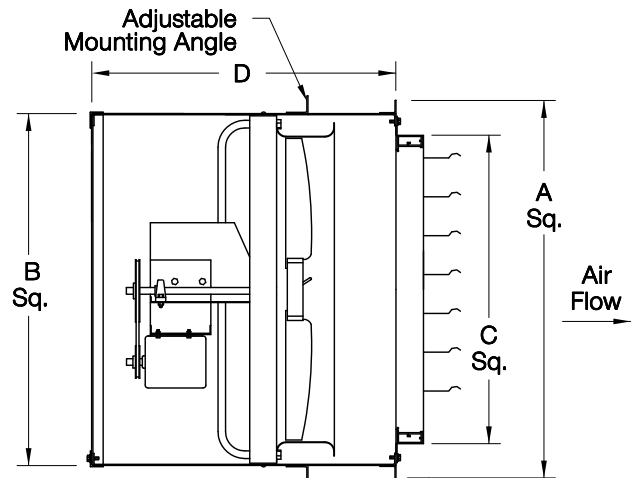

NOTE: Mounting angle is 2 pieces, shipped loose.

QTY	MARK	CATALOG NUMBER	FAN INFORMATION			MOTOR INFORMATION					ACCESSORIES								
			CFM	SP	RPM	HP	VOLTS	HZ	PH	TYPE									

LARGEST MOTOR SHIPPED MOUNTED: ODP (OPEN DRIP-PROOF) 3 HP; 2 SP (2 SPEED) 2 HP; X-PRF (EXPLOSION PROOF) 2 HP; TEFC (TOTALLY ENCLOSED FAN COOLED) 3 HP.

WP009R06