



COOK X-Stream

XMPH

DATE: _____

PROJECT: _____

LOCATION: _____

Heavy Duty Medium-Pressure Wall-Pac Exhaust Fan Steel Propeller Belt Drive



DIMENSION DATA

Size	A	B*	C	D*	Wall Opening	Wall Housing Gauge	Shipping Weight
20	27-1/2	25	22	37-3/8	25-1/4	18 GA.	195
24	33-1/2	31	27-1/2	37-3/8	31-1/4	18 GA.	241
30	39-1/2	37	33-1/2	38	37-1/4	18 GA.	295
36	45-1/2	43	39-1/2	39-1/2	43-1/4	18 GA.	362
42	51-1/2	49-1/16	45-1/2	41	49-1/4	16 GA.	482
48	57-1/2	55-1/16	51-1/2	51	55-1/4	16 GA.	596
54	63-1/2	61-1/8	57-1/2	48	61-1/2	14 GA.	721
60	69-1/2	67-1/8	63-1/2	48	67-1/2	14 GA.	795

ALL DIMENSIONS IN INCHES. SHIP WEIGHTS IN LBS., LESS MOTOR.
*B & D DIMENSIONS ARE TO OUTSIDE OF FASTENERS ON WALL HOUSING.

STANDARD CONSTRUCTION FEATURES:

X-stream steel propeller - Propeller hub keyed to shaft - Continuously welded wall panel corners - Galvanized steel wall housing - Adjustable mounting angle - Galvanized steel wire guard - Galvanized exhaust shutter - Heavy duty tubular steel power assembly - Lorenized powder paint finish on all uncoated steel parts - Corrosion resistant fasteners - 14 gauge steel venturi - Permanently lubricated ball bearing motor - Regreasable bearings in a cast housing rated at 200,000 hours average life - Adjustable pitch drives through 5 hp motor - Static resistant belts - All fans factory adjusted to specified RPM.

NOTE: Mounting angle is 2 pieces, shipped loose.

ACCESSORIES

1. DISCONNECT SWITCH
2. PRE-WIRED DISCONNECT SWITCH
3. PRE-WIRED DISCONNECT SWITCH WITH FLEXIBLE CONDUIT
4. ALUMINUM EXHAUST SHUTTER - GRAVITY OR MOTORIZED
5. ALUMINUM HD EXHAUST SHUTTER - GRAVITY OR MOTORIZED
6. WEATHERHOOD
7. KNOCKDOWN WEATHERHOOD
8. SHUTTER GUARD
9. ALUMINUM HOUSING
10. BAKED EPOXY POWDER
11. BAKED PHENOLIC EPOXY POWDER

Note: Correct propeller rotation is CCW when viewing from inlet side.

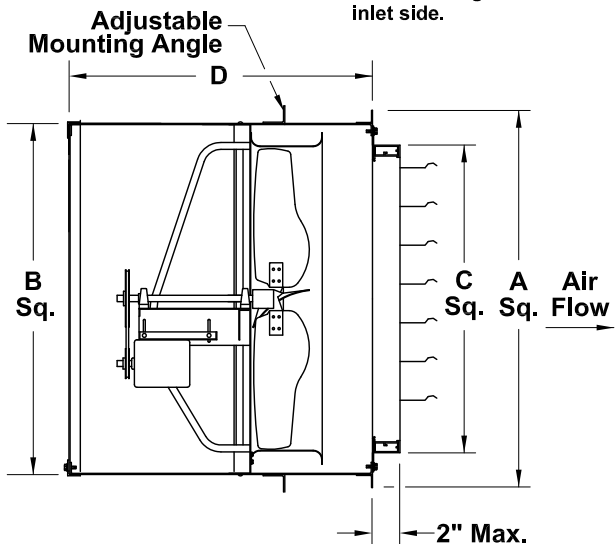

QTY	MARK	CATALOG NUMBER	FAN INFORMATION			MOTOR INFORMATION					ACCESSORIES				
			CFM	SP	RPM	HP	VOLTS	HZ	PH	TYPE					

LARGEST MOTOR SHIPPED MOUNTED: ODP (OPEN DRIP-PROOF) 5 HP; 2 SP (2 SPEED) 3 HP;
X-PRF (EXPLOSION PROOF) 3 HP; TEFC (TOTALLY ENCLOSED FAN COOLED) 5 HP.

WP026R04