



# COOK

# EDD

DATE: \_\_\_\_\_

PROJECT: \_\_\_\_\_

LOCATION: \_\_\_\_\_



## Tube Axial Drum Fan Extruded Aluminum Propeller Direct Drive

### DIMENSION DATA

Size	A	B	C	Drum Ga.	Ship Wt.
24	22	27-1/2	1-1/2	12 ga.	171
30	26-1/2	33-1/2	1-1/2	12 ga.	226
36	29	39-1/2	1-1/2	12 ga.	294
42	34-1/2	45-3/4	1-5/8	10 ga.	437
48	36-1/2	52-3/4	2-1/8	10 ga.	595

ALL DIMENSIONS IN INCHES. WEIGHTS IN LBS., LESS MOTOR.

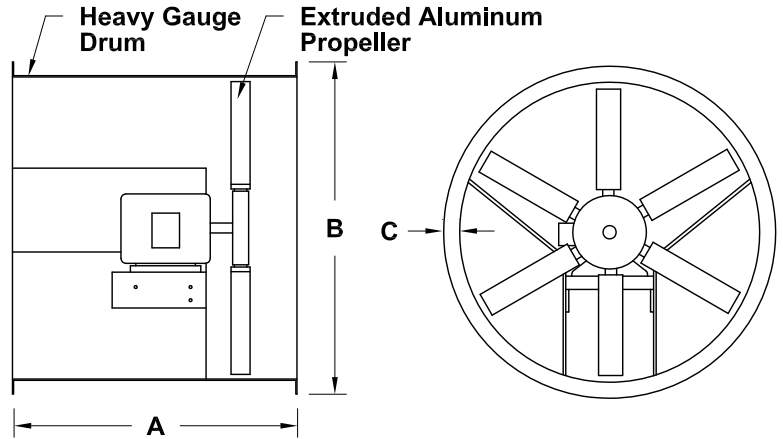

### STANDARD CONSTRUCTION FEATURES:

Extruded aluminum propeller - Painted steel housing - Permanently lubricated ball bearing motors - Corrosion resistant fasteners.

### ACCESSORIES

1. DISCONNECT SWITCH
2. INLET/OUTLET GUARD
3. FLOOR MOUNTING FEET
4. HANGING BRACKETS (V OR H)
5. INLET BELL
6. SPECIAL

QTY	MARK	CATALOG NUMBER	FAN INFORMATION			MOTOR INFORMATION					ACCESSORIES						
			CFM	SP	RPM	HP	VOLTS	HZ	PH	TYPE							

MOTOR TYPE: ODP (OPEN DRIP-PROOF); 2 SP (2 SPEED); X-PRF (EXPLOSION PROOF); TEFC (TOTALLY ENCLOSED FAN COOLED).

WP073R03