

DATE: _____
 PROJECT: _____
 LOCATION: _____

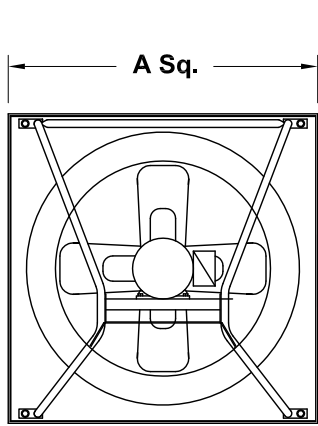

**Wall Fan
 Heavy Duty
 Aluminum Propeller
 Direct Drive**



****Rotation**

SIZE 12-18

**** Correct propeller rotation is CCW when viewing from inlet side.**

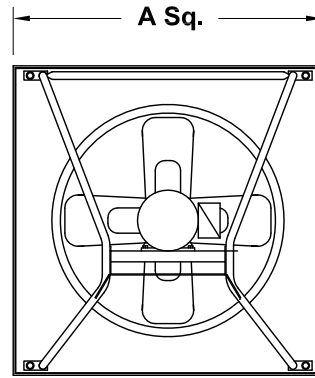
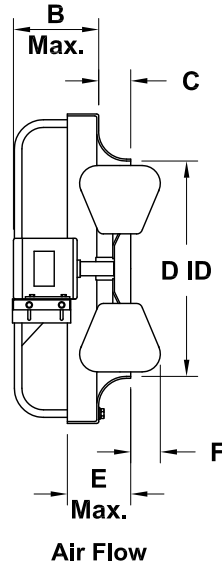

****Rotation**

SIZE 20-24

**** Correct propeller rotation is CCW when viewing from inlet side.**

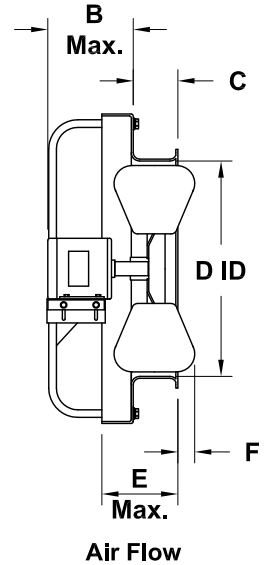

DIMENSION DATA

Size	A Sq.	B Max.	C	D Dia.	E	F	Wall Opening*	Approx. Ship Wt.
12	16-3/16	4-3/4	1-3/4	12-3/4	3-1/2	1-1/2	16-7/16	68
14	20-3/16	5-13/16	2-1/2	14-3/4	4-1/2	1-5/8	20-7/16	89
16	20-3/16	5-13/16	2-1/2	16-3/4	4-1/2	2	20-7/16	93
18	24-3/16	5-13/16	2-3/4	18-3/4	4-3/4	2-1/8	24-7/16	107
20	24-3/16	5-13/16	6-5/8	20-3/4	8-5/8	-5/8	24-7/16	113
24	30-3/16	6-1/16	6-5/8	25	6-5/8	5/8	30-7/16	140

ALL DIMENSIONS IN INCHES. WEIGHTS IN LBS., INCLUDES ODP MOTOR.
 * See wire guard or wall collar submittal for accessory wall opening.

STANDARD CONSTRUCTION FEATURES:

Aluminum propeller blades attached to a steel hub - Propellers are statically and dynamically balanced - 14 gauge steel venturi - Welded wall base corners - Heavy duty steel power assembly - Lorenized powder paint finish - Corrosion resistant fasteners.

ACCESSORIES

1. GALVANIZED SHUTTER - GRAVITY OR MOTORIZED
2. ALUMINUM SHUTTER - GRAVITY OR MOTORIZED
3. BAKED EPOXY POWDER
4. BAKED PHENOLIC EPOXY POWDER
5. PROP SIDE WIRE GUARD
6. MOTOR SIDE WIRE GUARD
7. WALL COLLAR
8. WEATHER HOOD
9. SHUTTER GUARD
10. DISCONNECT SWITCH
11. FAN SPEED CONTROL

QTY	MARK	CATALOG NUMBER	FAN INFORMATION			MOTOR INFORMATION					ACCESSORIES	
			CFM	SP	RPM	HP	VOLTS	HZ	PH	TYPE		

MOTOR TYPE: ODP (OPEN DRIP-PROOF).