

DATE: \_\_\_\_\_

PROJECT: \_\_\_\_\_

LOCATION: \_\_\_\_\_



**Packaged Wall Fan  
Heavy Duty  
Aluminum Propeller  
Direct Drive**

**DIMENSION DATA**

Size	A Sq.	B Sq.*	C Sq.	D*	Wall Opening	Wall Housing Gauge	Approx. Ship Wt.
12	19-1/2	17	14	17-3/4	17-1/4	18 Ga.	76
14	23-1/2	21	18	22-1/4	21-1/4	18 Ga.	82
16	23-1/2	21	18	22-1/4	21-1/4	18 Ga.	95
18	27-1/2	25	22	23-1/4	25-1/4	18 Ga.	120
20	27-1/2	25	22	23-1/4	25-1/4	18 Ga.	139
24	33-1/2	31	27-1/2	27-1/4	31-1/4	18 Ga.	151

ALL DIMENSIONS IN INCHES. SHIP WEIGHTS IN LBS.

\* B-SQ & D DIMENSIONS ARE TO THE OUTSIDE OF FASTENERS ON WALL HOUSING.

**STANDARD CONSTRUCTION FEATURES:**

Aluminum propeller blades attached to a steel hub - Plated steel motor mount/wire guard - Spun steel Venturi/wall base - Galvanized steel wall housing - Galvanized steel exhaust shutter - 1/2" mesh galvanized screen on inlet - Corrosion resistant fasteners - Welded wall base corners.

**ACCESSORIES**

1. DISCONNECT SWITCH
2. DISCONNECT SWITCH PREWIRED
3. DISCONNECT SWITCH PREWIRED IN FLEX CONDUIT
4. GALVANIZED AUTOMATIC SHUTTER
5. ALUMINUM AUTOMATIC SHUTTER
6. GALVANIZED SHUTTER MOTORIZED
7. ALUMINUM SHUTTER MOTORIZED
8. EPOXY POWDER
9. PHENOLIC EPOXY POWDER
10. PHENOLIC EPOXY POWDER WITH UV
11. PRIMER COATING
12. FAN SPEED CONTROL
13. SHUTTER GUARD
14. WEATHER HOOD

Note: Correct propeller rotation is CCW when viewing from Inlet slide.

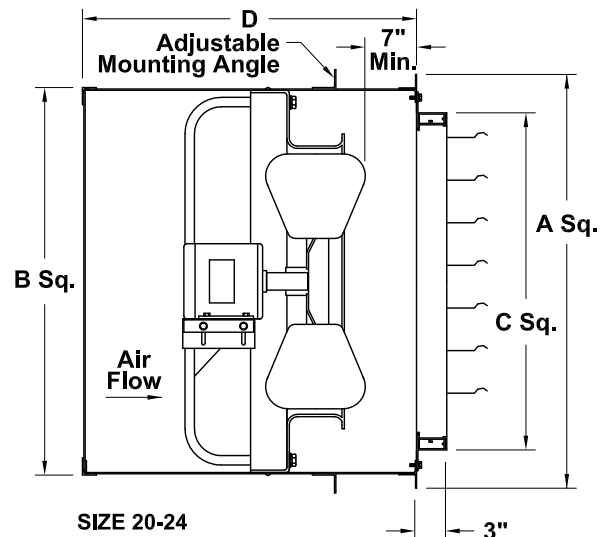
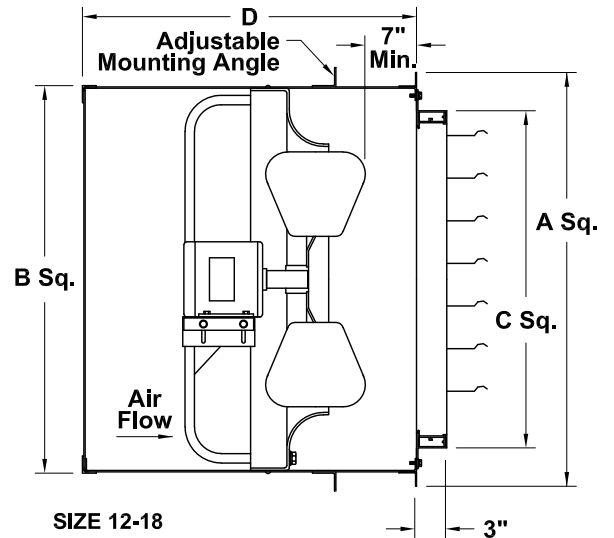

NOTE: MOUNTING ANGLE IS 2 PIECES, SHIPPED LOOSE

QTY	MARK	CATALOG NUMBER	FAN INFORMATION			MOTOR INFORMATION					ACCESSORIES	
			CFM	SP	RPM	HP	VOLTS	HZ	PH	TYPE		

MOTOR TYPE: ODP (OPEN DRIP-PROOF).